

LINCOLN

®

LUBRICATION TOOLS & EQUIPMENT

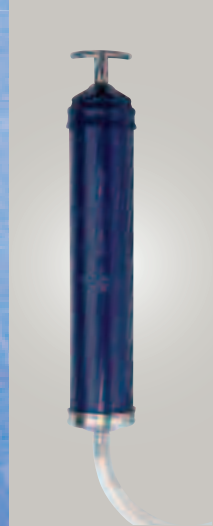

People, Capabilities and Systems to Save Money and Increase Productivity



Industry Leader

Continually satisfying our customers with the world's best lubrication equipment and pumping systems has made Lincoln the largest and most successful company in our field. For more than 90 years, companies have relied on our technical and quality leadership; our world-class manufacturing and customer service, and our vast network of distributors and support facilities.

Research and Development

In order to provide the best worldwide and regional application solutions, Lincoln develops new products and systems at research and development facilities in the United States, Germany and India.

Providing Solutions

Industrial customers in large processing plants, automotive manufacturing, pulp and paper mills, food and beverage and other manufacturing facilities can depend on solutions from Lincoln. For the toughest mobile applications, on the road or in the field, Lincoln protects heavy equipment used in mining, construction, agriculture and over-the-road trucking. In addition, Lincoln offers the best lubrication equipment to meet the needs of automotive service professionals.

Complete Product Line

Lincoln supplies automated lubrication systems, pumps and pump stations and top quality lubrication equipment and accessories. Our quality systems in the United States and Germany are ISO 9001 registered and our fittings business is QS 9000 registered.

Worldwide Support

With five technical support centers on three continents, and a network of distributors supported by regional sales and service offices, our customers can always draw on our worldwide resources.



2	Hand Held Lubrication & Accessories	
	PMV Pump Family	.2
	PMV Portable Pumps	.3
	3" PMV Grease Pumps—Stationary and Replacement	.4
	4.25" PMV Grease Pumps—Stationary	.5
	3" PMV Oil Pumps	.6
	4.25" PMV Oil Pumps	.7
	PMV Pump Specifications	.8
	PowerLuber®	.9
	Grease Guns	.11
	Clear Grease Guns	.14
	Grease Hose Extensions	.15
	Grease Accessories	.16
	Fittings	.20
	Wheel Bearing Packers	.21
22	Pumps & Accessories	
	High-Pressure Grease Pumps & Accessories	.22
	Medium-Pressure Oil Pumps & Accessories	.29
	Bulk Oil Systems	.35
	Value Series 1:1 and 3.5:1 Pumps	.36
	Transfer Pumps	.37
38	Used Fluid Equipment & Accessories	
	Oil Drains & Accessories	.38
	Fluid Recovery & Accessories	.40
	Mityvac Fluid Transfer & Evacuation Equipment	.41
	Installed Fluid Evacuation & Disposal Systems	.42
43	Hose Reels & Accessories	
	94000 Series	.43
	Heavy-Duty	.45
	High-Flow	.46
	Dual Arm	.47
	Value Series	.48
	Hose/Hose Adapters	.49
50	Control Valves & Meters	
	Grease	.50
	Fluid Lubricants	.51
	Air/Water	.54
55	Air Line Products	
	Air Couplers and Nipples	.55
	Air Sprayers and Valves	.57
	Air Controls & Accessories	.58
	Regulators, Filters and Lubricators	.59
	AirCare™ Air Preparation Systems	.60
68	Safety Warning Information	.68
69	Numerical Index	.69



Merchandising Displays Inside Back Cover

Designed for Exceptional Performance, Long Service Life, Low Maintenance Cost

Lincoln's new PMV family of grease and oil pumps represents 100 years of high-quality engineering, technology and manufacturing. The unique, modular design of these pumps includes precision-machined parts made with durable materials which allows for a longer pump life.

Based on Lincoln's proven PowerMaster III air logic pump technology, PMV is a simple design with few moving parts. This translates to exceptional performance, long service life and low maintenance cost.



PMV Features and Benefits

Air Valve Assembly

- Proven design based on the PowerMaster III air logic pump technology
 - More than 25 years of precision pump engineering ensures dependable, quiet performance
- Modular, fastened by four bolts
 - Quick and easy to maintain throughout the service life of the pump
- Precision machined and made from aircraft aluminum
 - Precise, durable and less susceptible to temperature than plastic spools
- Runs without external lubrication
 - Reduces cost of ownership
- No springs, rods, levers or slides
 - Fewer parts to wear out, increasing durability, decreasing repair cost
- Designed to work in a contaminated air supply
 - Airline filters that have not been drained will not affect the air motor's performance



Pump Tube

- One-piece, machined gland nut
 - Easy to maintain over the life of the pump
- Divorced pump tube and air motor seal
 - Air motor seal is a separate o-ring which reduces the chance of contamination in the motor



Pump Seals

- Made from durable polyurethane
 - Compatible with a wide range of natural and synthetic lubricants

Pump Rod

- Hard-chrome plated
 - Allows for superior sealing which extends the life of the rod



Air Cylinder

- One-piece cylinder casting contains all ports and passages
 - Simplifies repairs
- One-piece piston
 - No connection to any rods, spools, springs or poppets reduces premature mechanical failures, simplifies repairs
- One o-ring on the piston
 - Reduces leak paths, improves durability





9989

9989 for 50:1 – 25-, 50-lb. Pails

Package Includes:

- Bare Pump Model No. 85791
 - Drum Cover Model No. 275370
 - Flexible Follower Plate Model No. 84775
 - Air Coupler/Nipple Model No. 5874/5875
 - 7' Grease Hose Model No. 75084
 - Straight Swivel Model No. 82399
 - Universal Swivel Model No. 81387
 - Control Valve Model No. 740



9917

9917 for 50:1 – 120-lb. Drums

Package Includes:

- Bare Pump Model No. 85792
 - Drum Cover Model No. 46007
 - Flexible Follower Plate Model No. 84780
 - Air Coupler/Nipple Model No. 5874/5875
 - 7' Grease Hose Model No. 75084
 - Straight Swivel Model No. 82399
 - Universal Swivel Model No. 81387
 - Control Valve Model No. 740
 - Caster Base Model No. 80895

Accessories (included with 9917, 9989 shown above)

Follower Plates

Model 84775

Deluxe universal follower for use with 25-50 lb. containers and 1", 1¼", 1½", 1⅝" diameter pump tubes. All rubber unit ensures complete grease dispensing to the bottom of dented or plastic lined drums; wipes pail or drum clean. Metal cap holds insert firmly in place, ensuring seal and maintaining vacuum.

Model 84780

Same as 84775 above but for 120 lb. containers and 1", 1¼", 1½", 1⅝", 2⅞" diameter pump tubes.



84775



84780



81387



740

Model 81387 Universal Swivel

½"-27(m) x ¼" NPT(m)

Model 740 Heavy-Duty High-Pressure

- 7500 psi maximum operating pressure
- Precision-machined, all steel handle, body and guard bracket provides durability and longevity
- Unique, precision control inlet check valve provides ease of handle operation even with increase in pressure
- Knurled handle for positive grip
- Handy trigger guard prevents pinching
- Reversible inlet check seat and hydraulic jaws provide double life
- Balanced design reduces user fatigue
- Lubricant inlet ¼" NPT(f); outlet ⅛" NPT(f)
- Easily repaired for extended life

Lubrication Tools and Equipment

3" PMV Grease Pumps—Stationary and Replacement



MODEL NO.	DESCRIPTION
50:1 — 3" 25-, 50-lb. Models	
85791	Bare Replacement Pump for 9989
50:1 — 3" 120-lb. Models	
85792	Bare Replacement Pump for 9917
V350120DC	Stationary Package
V350120000	Bare Pump
K050120DC	120-lb. Stationary Kit
85826	<i>Drum Cover</i>
10198	<i>(2) Hose Connectors</i>
80202	<i>Elbow Union</i>
75060	<i>1/4" x 5' Grease Hose</i>
273299	<i>3/8" x 5' Air Hose</i>
84780	<i>Follower</i>
5874/5875	<i>Air Coupler/Nipple</i>
V350120HF	Inductor Package
V350120000	Bare Pump
274932	Hoist/Follower Kit
V350120LT	Lube Truck Package
V350120000	Bare Pump
K050120LT	120-lb. Lube Truck Kit
85829	<i>120-lb. Drum Cover with Tie Downs</i>
80202	<i>Elbow Union</i>
5874/5875	<i>Air Coupler/Nipple</i>
275415	<i>Lifting Eye</i>
50:1 — 3" 400-lb. Models	
V350400000	Bare Pump
V350400DC	Stationary Package
V350400000	Bare Pump
K050400DC	400-lb. Drum Cover Kit
85827	<i>Drum Cover</i>
10198	<i>(2) Hose Connectors</i>
80202	<i>Elbow Union</i>
75060	<i>1/4" x 5' Grease Hose</i>
273299	<i>3/8" x 5' Air Hose</i>
5874/5875	<i>Air Coupler/Nipple</i>
V350400HF (not shown)	Inductor Package
V350400000	Bare Pump
275260	Hoist/Follower Kit
V350400LT	Lube Truck Package
V350400000	Bare Pump
K050400LT	400-lb. Lube Truck Kit
85829	<i>400-lb. Drum Cover with Tie Downs</i>
80202	<i>Elbow Union</i>
5874/5875	<i>Air Coupler/Nipple</i>
275415	<i>Lifting Eye</i>

Lubrication Tools and Equipment

4.25" PMV Grease Pumps—Stationary



MODEL NO.	DESCRIPTION
50:1 — 4.25" 120-lb. Models	
V4501200000 (not shown)	Bare Pump
V450120DC	Stationary Package
V450120000	Bare Pump
K050120DC	120-lb. Stationary Kit
85826	Drum Cover
10198	(2) Hose Connectors
80202	Elbow Union
75060	1/4" x 5' Grease Hose
273299	3/8" x 5' Air Hose
84780	Follower
5874/5875	Air Coupler/Nipple
V450120LT	Lube Truck Package
V450120000	Bare Pump
K050120LT	120-lb. Lube Truck Kit
84829	120-lb. Drum Cover with Tie Downs
80202	Elbow Union
5874/5875	Air Coupler/Nipple
275416	Lifting Eye
50:1 — 4.25" 400-lb. Models	
V4504000000	Bare Pump
V450400DC	Stationary Package
V450400000	Bare Pump
K050400DC	400-lb. Drum Cover Kit
85827	Drum Cover
10198	(2) Hose Connectors
80202	Elbow Union
75060	1/4" x 5' Grease Hose
273299	3/8" x 5' Air Hose
5874/5875	Air Coupler/Nipple
V450400HF	Inductor Package
V450400000	Bare Pump
275260	Hoist/Follower Kit
V450400HR	Inductor/Runaway Package
V450400000	Bare Pump
85840	Runaway Control
275260	Hoist/Follower Kit
V450400LT	Lube Truck Package
V450400000	Bare Pump
K050400LT	400-lb. Lube Truck Kit
83115	400-lb. Drum Cover with Tie Rods
80202	Elbow Union
5874/5875	Air Coupler/Nipple
275416	Lifting Eye

Lubrication Tools and Equipment

3" PMV Oil Pumps



MODEL NO.	DESCRIPTION
5:1 — 3" MODELS	
V305000000	Bare Pump
V30500SSU	Stub/Universal Pump
V305000000	Bare Pump
K00000SSU	Stub/Universal Kit
85824	Bung Bushing
5874/5875	Air Coupler/Nipple
72024A	3/8" x 2' Air Hose
73024	1/2" x 2' Fluid Hose
241584	90° Swivel
V305055BB	55-Gallon Pump
V305000000	Bare Pump
K000055BB	Stub/Universal Kit
85824	Bung Bushing
5874/5875	Air Coupler/Nipple
273299	3/8" x 5' Air Hose
73060	1/2" x 5' Fluid Hose
85807	Down Tube
241584	90° Swivel
V305016DC	16-Gallon Pump
V305000000	Bare Pump
K000016DC	Drum Cover Kit
85826	Drum Cover
5874/5875	Air Coupler/Nipple
273299	3/8" x 5' Air Hose
73060	1/2" x 5' Fluid Hose
85806	Suction Tube
V305275BB	275-Gallon Pump
V305000000	Bare Pump
K000275BB	275-Gallon Pump Mount Kit
85824	Bung Bushing
5874/5875	Air Coupler/Nipple
273299	3/8" x 5' Air Hose
73060	1/2" x 5' Fluid Hose
85949	Universal Suction Tube
V30500SWM	Wall Mount Pump
V305000000	Bare Pump
84945	Remote Suction Kit
275398	Wall Mount Kit
5874/5875	Air Coupler/Nipple
273299	3/8" x 5' Air Hose
73060	1/2" x 5' Fluid Hose
241584	90° Swivel
275413	Wall Mount Assembly
V305055LT	55-Gallon Lube Truck Pump
V305000000	Bare Pump
K000055LT	Drum Cover and Hose Kit
83115	400-lb. Drum Cover with Tie Rods
85807	Down Tube
275415	Lifting Eye
5874/5875	Air Coupler/Nipple
273299	3/8" x 5' Air Hose

Lubrication Tools and Equipment

4.25" PMV Oil Pumps



MODEL NO.	DESCRIPTION
6:1 — 4.25" Models	
V406000000	Bare Pump
V40600SSU	Stub Pump
V406000000	Bare Pump
K40600SSU	6:1 Stub Kit
5874/5875	Air Coupler/Nipple
72024A	3/8" x 2' Air Hose
73024	1/2" x 2' Fluid Hose
241584	90° Swivel
V40600SWM	Wall Mount Pump
V406000000	Bare Pump
84945	Remote Suction Kit
275398	Wall Mount Kit
5874/5875	Air Coupler/Nipple
273299	3/8" x 5' Air Hose
73060	1/2" x 5' Fluid Hose
241584	90° Swivel
275413	Wall Mount Assembly
10:1 — 4.25" Models	
V410000000	10:1 Bare Pump
V41000SSU	10:1 Stub/Universal Pump
V410000000	Bare Pump
K00000SSU	Stub/Universal Kit
85824	Bung Bushing
5874/5875	Air Coupler/Nipple
72024A	3/8" x 2' Air Hose
73024	1/2" x 2' Fluid Hose
241584	90° Swivel
V410055DC	55-Gallon Pump with Drum Cover
V410000000	Bare Pump
K000055DC	55-Gallon Drum Cover Kit
85827	Drum Cover
5874/5875	Air Coupler/Nipple
273299	3/8" x 5' Air Hose
73060	1/2" x 5' Fluid Hose
85807	Suction Tube
241584	90° Swivel
V410055BB	55-Gallon Pump with Bung Bushing
V410000000	Bare Pump
K000055BB	55-Gallon Bung Mount Kit
85824	Bung Bushing
5874/5875	Air Coupler/Nipple
273299	3/8" x 5' Air Hose
85807	Down Tube
241584	90° Swivel
V41000SWM	Wall Mount Pump
V410000000	Bare Pump
84945	Remote Suction Kit
275398	Wall Mount Kit
5874/5875	Air Coupler/Nipple
273299	3/8" x 5' Air Hose
73060	1/2" x 5' Fluid Hose
241584	90° Swivel
275413	Wall Mount Assembly
V410055LT	55-Gal. Lube Truck Pump with Drum Cover
V410000000	Bare Pump
K000055LT	Drum Cover and Hose Kit
83115	400-lb. Drum Cover with Tie Rods
85807	Down Tube
275415	Lifting Eye
5874/5875	Air Coupler/Nipple
273299	3/8" x 5' Air Hose
V410055LB	55-Gal. Lube Truck Pump with Bung Bushing
V410000000	Bare Pump
K000055LB	55-Gallon Lube Truck Kit with Bung Bushing
85824	Bung Bushing
83131	Tie Rod Kit
85807	Suction Tube
5874/5875	Air Coupler/Nipple
273299	3/8" x 5' Air Hose

6:1 PUMPS FOR STUB OR WALL MOUNT ONLY. NOT FOR USE WITH BUNG BUSHINGS.

50:1 3" Grease Pumps

Pumping Ratio	50:1
Air Pressure	40-150 psi (2.7-10.3 bar)
Max. Output Pressure	7500 psi (517 bar)
Air Inlet	3/8 NPTF
Material Outlet	1/4 NPTF
Airmotor Bore Dia.	3 in. (76.2 mm)
Stroke	3 1/4 in. (82.5 mm)
Output Per Cycle	0.78 cu. in. (12.8 cc)
Wetted Parts	Carbon Steel, Brass, Zinc, Polyurethane, Nitrile
Free Flow	168 in ³ /min (2753 cc/min)
Overall Length (35 Lb.)	27 5/8" (708 mm)
Overall Length (120 Lb.)	36 3/8" (924 mm)
Overall Length (400 Lb.)	42 7/8" (1089 mm)

Decibels less than 85 at all normal operating conditions

5:1 3" Oil Pumps

Pumping Ratio	5:1
Air Pressure	40-150 psi (2.7-10.3 bar)
Max. Output Pressure	750 psi (51 bar)
Air Inlet	3/8 NPTF
Material Outlet	1/2 NPTF
Material Inlet	1 1/2 NPTF
Airmotor Bore Dia.	3 in. (76.2 mm)
Stroke	3 1/4 in. (82.5 mm)
Output Per Cycle	6.7 cu. in. (110 cc)
Cycles/Gal (Liter)	34.5 (9.1)
Wetted Parts	Carbon Steel, Brass, Zinc, Polyurethane, Nitrile
Free Flow	7 gpm (26.5 lpm)
Overall Length (Stub)	17 3/8" (442 mm)

Decibels less than 85 at all normal operating conditions

10:1 4.25" Oil Pumps

Pumping Ratio	10:1
Air Pressure	40-150 psi (2.7-10.3 bar)
Max. Output Pressure	1500 psi (103 bar)
Air Inlet	3/8 NPTF
Material Outlet	1/2 NPTF
Material Inlet	1 1/2 NPTF
Airmotor Bore Dia.	4 1/4 in. (108 mm)
Stroke	3 1/4 in. (82.5 mm)
Output Per Cycle	7.2 cu. in. (118 cc)
Cycles/Gal (Liter)	32.1 (8.5)
Wetted Parts	Carbon Steel, Brass, Zinc, Polyurethane, Nitrile
Free Flow	5 gpm (18.4 lpm)
Overall Length (Stub)	17 7/8" (443 mm)

Decibels less than 85 at all normal operating conditions

50:1 4.25" Grease Pumps

Pumping Ratio	50:1
Air Pressure	40-150 psi (2.7-10.3 bar)
Max. Output Pressure	7500 psi (517 bar)
Air Inlet	3/8 NPTF
Material Outlet	1/4 NPTF
Airmotor Bore Dia.	4 1/4 in. (108 mm)
Stroke	3 1/4 in. (82.5 mm)
Output Per Cycle	1.47 cu. in. (24.1 cc)
Wetted Parts	Carbon Steel, Brass, Zinc, Polyurethane, Nitrile
Free Flow	220 in ³ /min (3605 cc/min)
Overall Length (120 Lb.)	36 7/8" (926 mm)
Overall Length (400 Lb.)	42 15/16" (1091 mm)

Decibels less than 85 at all normal operating conditions

6:1 4.25" Oil Pumps

Pumping Ratio	6:1
Air Pressure	40-150 psi (2.7 -10.3 bar)
Max. Output Pressure	900 psi (62 bar)
Air Inlet	3/8 NPTF
Material Outlet	1/2 NPTF
Material Inlet	1 1/2 NPTF
Airmotor Bore Dia.	4 1/4 in. (108 mm)
Stroke	3 1/4 in. (82.5 mm)
Output Per Cycle	11.9 cu. in. (195 cc)
Cycles/Gal (Liter)	19.4 (5.1)
Wetted Parts	Carbon Steel, Brass, Zinc, Polyurethane, Nitrile
Free Flow	7 gpm (26.5 lpm)
Overall Length	18 7/8" (480 mm)

Decibels less than 85 at all normal operating conditions

NOTE:

6:1 pumps for stub or wall mount only. Not for use with bung bushings. Use the suction kit and wall mount bracket that are packaged with the pump assembly model.

Professional Two-Speed 14.4-Volt Cordless Grease Gun

For years, Lincoln's PowerLuber has been the favorite of technicians, mechanics, maintenance crews, farmers and others for almost every lubrication and preventative maintenance task imaginable, from the automotive, trucking and fleet industries to everyday applications in agriculture, construction and industry.

Now, we've made the best even better. PowerLuber's versatile two-speed design gives it the capability of two powerful tools in one. At the touch of a button, it can deliver high volumes of lubricant (8.5 oz. per minute) at medium pressure or a concentrated stream at high pressure (7500 psi working pressure). We've also added a built-in stroke indicator to make it easy to measure total output.

Even with all that power, the long-lasting, high amperage 14.4 volt battery lets you work longer between recharges. When you do need to recharge, our high-tech "Smart" Charger does it in less than one hour. The "Smart" Charger even recognizes battery condition when not in use, and keeps your battery ready to go.

The 14.4 V PowerLuber's balanced design and padded grip make this tool comfortable and easy to use.



PowerLuber 14.4 Features

- Powerful 14.4 volt high-torque motor
 - 7,500 psi working output pressure
 - 8.5 oz/min. grease output @ 1,000 psi
- Machined and hardened piston
- Slotted powerhead accepts shoulder strap (strap sold separately)
- Includes combination air bleeder/filler valve
- Accessibility allows for easy cleaning from contaminated grease without gun disassembly
- Plated steel barrel with exclusive flip-over follower
- One-hour "smart" charger
 - up to eight grease cartridges dispensed per charge under free-flow test conditions
- High-capacity NiCad 14.4-volt battery
- 30" high-pressure hose with spring guard and coupler

Model 1442

Packed in a heavy-duty compact case molded from impact- and stain-resistant plastic, Model 1442 comes complete with the 14.4 V PowerLuber and battery, a 110 Volt one-hour "Smart" Charger (Model 1410), and a 30" flex hose with spring guard (Model 1230).

Model 1444

Includes the same contents as Model 1442 plus a second 14.4-volt NiCad rechargeable battery (Model 1401) for uninterrupted lube application.

Model 1400

14.4V PowerLuber and battery only.



Multi-speed output selector** – control the powerful two-speed transmission with just a push



Stroke cycle indicator pin – lets you monitor total output by touch



Motor overload protection – reset breaker protects motor from overload

** High output setting (H) delivers 2.5 times the volume as lower output setting (L).



Model 1242

The standard PowerLuber 1242 comes outfitted with a heavy-duty carrying case. Comes complete with:

- 110-volt fast charger (model 1210)
- 12-volt NiCad rechargeable battery (model 1201)
- 30" flex hose with spring guard (model 1230)

Model 1244

Top of the line. Includes second 12-volt rechargeable battery 1201 for uninterrupted lube application.

Model 1240

Economy packed without carrying case. Includes one 12-volt rechargeable battery 1201 and battery charger 1210.

Model 1200

PowerLuber and battery only.

PowerLuber Accessories

Batteries

High quality NiCad rechargeable PowerLuber batteries. **Model 1401** (14.4v),

Model 1201 (12.0v), **Model 1203** (7.2v), **Model 1227** (3.6v).

Whip Hoses

Attach to PowerLuber with 7/16" UNEF fitting, 1/8" NPT(m) outlet.

Working pressure 7500 psi (517 bar). **Model 1218** (18"), **1224** (24"), **1230** (30") and **1236** (36").

Chargers

Model 1410

"Smart" charger recharges batteries in less than one hour and recognizes battery condition when not in use. For use with Model 1442 and 1444. **Model 1210**—110-volt one-hour fast charger for use with battery pack 1201. 6 ft. cord; UL/ULC listed. Also Model 1211 for 7.2-volt PowerLuber.

Model 1215

12-volt to 12-volt DC field charger for use with battery pack 1201

(plugs into

cigarette lighter). **Model 1215A** allows use of both 12-volt and 24-volt DC input.

Model 1415A

14.4-volt DC field charger. Allows use of both 12-volt and 24-volt DC input.

Model 1414

Shoulder strap for hands-free movement from job to job.





1142

Lincoln. . . the brand the pros demand for quality lubrication tools

For over 90 years the industry has recognized Lincoln as the leader in professional lubrication tools.

Professional automotive, agricultural and industrial mechanics depend on Lincoln tools for their livelihood. Lincoln tools offer a lifetime of performance and are backed by the most comprehensive warranty in the industry.

Lincoln hand-held grease guns offer:

- Rugged cast pump head for strength and durability.
- Jam-proof toggle mechanism prevents binding or accidental bending of plunger.
- Exclusive "Flip-Over" follower allows a superior seal for either cartridge or bulk loading applications. Tough, resilient and impervious to lubricant.
- Extra-heavy follower spring insures positive priming and uninterrupted pumping action.
- Accessible check valve allows easy cleaning without gun disassembly.
- Precision fit and hardened plunger prevents lubricant bypass, resists scoring for longer life.
- Follower rod locks into follower to force prime.

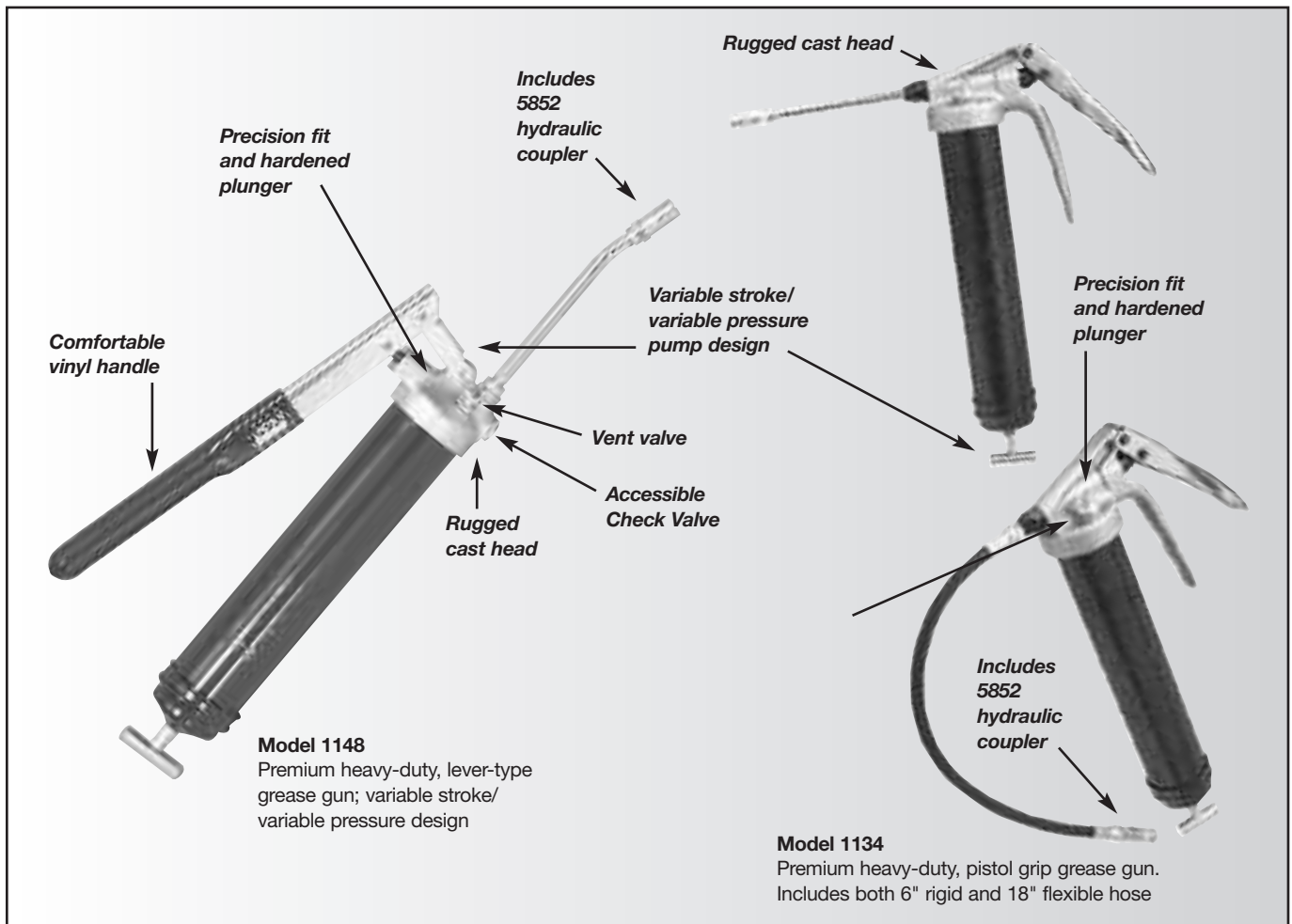

Heavy-Duty Lever Type

Model 1142

First choice of users everywhere.

Model 1147

Same as 1142 with 18" whip hose and coupler; flip-over follower set for cartridge use.

Model 1148

Premium version of our popular model 1142. This pump head includes dual grease inlet ports that provide the user the option of high pressure or high volume delivery. The tool also includes a comfortable vinyl grip and vent valve for purging air.

Model 1151

Same as 1142 but holds 21 ounces bulk; flip-over follower set for bulk loading.

Heavy-Duty Pistol Grip Type

Model 1132

Fast, one-hand operation with similar features and benefits of Lincoln lever-type grease guns. Includes 5" extension with coupler.

Model 1133

Same as 1132 with 18" whip hose and coupler.

Model 1134

Extra-heavy-duty pistol grip grease gun. Cast head design. Jam proof handle return mechanism. Develops up to 7500 psi. Includes both 18" whip hose with coupler and 6" rigid tube. Variable stroke/pressure design.

Model 91108 Filler Nipple

Enables hand guns to be loaded using filler pump method. Includes ball check; 1/8" NPT(m).

Model 82760 Grease Gun Holder

Can be mounted to almost any surface. Holds grease guns and suction guns with 2 1/4" OD barrel. Holds guns until ready to use.



Grease Guns Lever Type

Model	Lube Capacity	Extension	Length
1142*	16oz. Bulk/14.5oz. Cartridge	5853	21 3/4"
1148*	16oz. Bulk/14.5oz. Cartridge	5853	21 3/4"
1147*	16oz. Bulk/14.5oz. Cartridge	71518 18" Hose & 5852 coupler	21 3/4"
1151**	21oz. Bulk/14.5oz. Cartridge	5853	24 1/2"

Specifications: Output 1oz. per 33 strokes using No. 1 grease at 70°F. Barrel diameter 2 1/4"

*Follower set for cartridge use. **Follower set for bulk loading.

Grease Guns Pistol Grip

Model	Lube Capacity	Extension	Length
1133*	16oz. Bulk/14.5oz. Cartridge	71518 18" Flex Hose & 5852 coupler	15 1/2"
1132*	16oz. Bulk/14.5oz. Cartridge	67020 6" Straight Pipe & 5852 coupler	15 1/2"
1134	16oz. Bulk/14.5oz. Cartridge	18" Flex Hose, 4" Straight Pipe & Coupler	15 1/2"

Specifications: Output 1oz. per 33 strokes using No. 1 grease at 70°F. Barrel diameter 2 1/4"

*Follower set for cartridge use.



Air-Operated

Model 1162 PowerLuber®

- Fully automatic, pneumatic grease gun with variable-speed trigger
- Outstanding performance, durability and grease flow
- Patented anti-cavitation pump
- 6000 psi greasing capability
- Air operating range 40-150 psi
- Accessible check valve for easy clean out
- Includes advanced vent valve with filler nipple
- 30" high-pressure hose
- Low operational noise

Dual-Pressure

Model 1013 and 1145

- High or low pressure for light- or heavy-duty greasing action
- Full pressure on short strokes for heavy greasing in tight places; develops full pressure with just 1/4" stroke
- Extension swivels 360° for hard-to-reach fittings.
- Plated barrel, head and handle
- Handy three-way loading: cartridge, filler pump or bulk
- Grease resistant rubber handle grip for positive pumping action

Precision High-Pressure and Volume

Model 1035 & 1037

- Exclusive toggle mechanism design uses compound leverage for high-pressure pumping with little effort
- Rust resistant plated gun barrel and handle, black enamel head.
- Equipped with filler nipple for fast refill from Lincoln filler pump
- 21 oz. bulk capacity for heavy-duty greasing applications

Load Pin in Rear Position for High-Output Delivery

With handle in REAR (lo) shift position, grease is delivered at low pressure (maximum 6000 psi) with strokes from 1/4" to 12". Output 1 ounce per 18 full strokes.

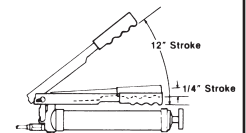

Load Pin in Front Position for High-Pressure Delivery

With handle in FRONT (hi) shift position, grease is delivered at high pressure (maximum 7000 psi) with strokes from 1/4" to 9". Output 1 ounce per 33 full strokes.

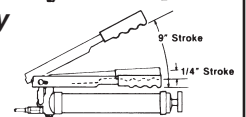

Dual-Pressure

Model	Lube Capacity	Extension	Length	Max. Pressure
1013	16oz. Bulk/14.5oz. Cartridge	5853	22 7/8"	7000/4000 psi
1145	21oz. Bulk/14.5oz. Cartridge	5853	25 1/4"	7000/4000 psi

Specifications: Output at **low pressure** 1oz. per 18 strokes; at **high pressure** 1 oz. per 33 strokes using No. 1 cup grease at 70°F. Barrel diameter 2 1/4".

High-Pressure

Model	Lube Capacity	Extension	Length	Max. Pressure
1035	21oz. bulk/14.5oz. cartridge	5834	27 1/4"	7000 psi

Specifications: Lubricant output 1 oz. per 25 strokes using No. 1 cup grease at 70°F. Barrel diameter 2 1/4".

Volume

Model	Lube Capacity	Extension	Length	Max. Pressure
1037	21oz. bulk/14.5oz. cartridge	5834	27 1/4"	3000 psi

Specifications: Lubricant output 1 oz. per 9 strokes using No. 1 cup grease at 70°F. Barrel diameter 2 1/4".

Lincoln's New Premium Line of Clear Grease Guns for 100% Positive Grease Identification

Not All Grease Is Created Equally—Different equipment, machines, bearing types and vehicles require different types of grease. Proper identification of the grease once installed in a grease gun can be challenging. Lincoln's clear tube allows for quick grease identification eliminating the risk of mixing incompatible or unspecified greases.

Built to Last—The high strength clear tube and aircraft aluminum adapters create one of the most durable tube assemblies in the industry. Traditional steel tubes are subject to damage in the workplace through drops and hits from other tools. The Lincoln clear tube design is impervious to this type of damage. Its resilient shell eliminates waste from grease bypass.

Military Proven—Lincoln's clear tube design was developed successfully for military maintenance support. The clear tube is being used successfully in these harsh environments, and it provides the 100% grease identification they demand.



The clear design enables:

- Positive grease type identification (bulk or cartridge)
- Visual confirmation of quantity of grease remaining in tube (bulk)
- Visual confirmation of air pockets eliminating the loss of prime (bulk)
- Visual confirmation of grease separation or contamination (bulk)
- Perfect concentricity and resilience eliminates bypass (bulk or cartridge)
- Visual recognition of grease brand promotes quality of shop (cartridge)

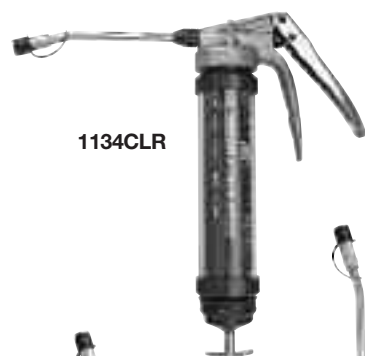

Clear Grease Gun Models

Model	Description
1100CLR	Clear Tube – for easy conversion from standard steel tubes
1107CLR	Clear Tube – for conversion of early model 1134s and many competitive models
1134CLR	Gun, HD Grease Pistol with Clear Tube
1142CLR	Gun, Lever with Clear Tube
1148CLR	Gun, Lever Deluxe with Clear Tube
1163CLR	Pneumatic Grease Gun with Clear Tube
1240CLR	12 V PowerLuber® with Clear Tube
1440CLR	14.4 V PowerLuber® with Clear Tube

Clear Tube Kits (1100CLR and 1107CLR) are available to allow the conversion of grease guns currently in use



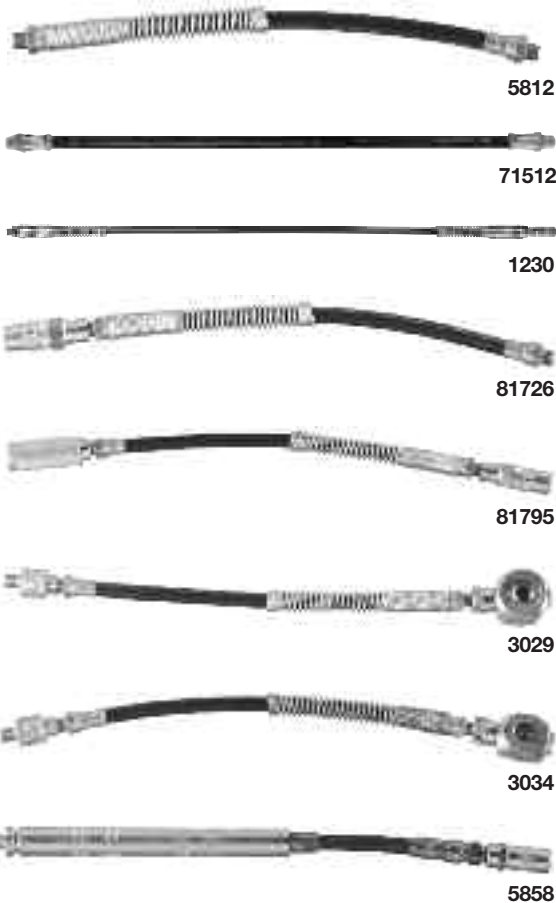

Extensions for Manually- or Air-Operated Grease Guns

Maximum working pressure 4500 psi. Strategically placed coil spring provides non-slip, push-pull grip and prevents accidental “kinking” which could cause hose ruptures.

Model	Length	Thread Size
5812	12"	1/8" NPT(m)
5818	18"	1/8" NPT(m)
5861	36"	1/8" NPT(m)

Extensions for Manually-Operated Grease Guns

Maximum working pressure 3000 psi.

Manually-Operated – Packaged

Model	Length	Thread Size
71512	12"	1/8" NPT(m)
71518	18"	1/8" NPT(m)

Manually-Operated – Bulk (Unpackaged)

Model	Length	Thread Size
75912CL	12"	1/8" NPT(m)
75918CL	18"	1/8" NPT(m)
75924CL	24"	1/8" NPT(m)
75936CL	36"	1/8" NPT(m)

PowerLuber® Whip Hoses

Attaches with 7/16" UNEF fitting; 1/8" NPT(m) outlet. Working pressure 7500 psi (517 bar). For use with 14.4-volt, 12-volt, 7.2-volt and Model 1163 PowerLubers.

Model	Length
1218	18"
1224	24"
1230	30"
1236	36"

Assemblies for Standard Hydraulic Fittings

Maximum working pressure 4500 psi.

Model	Whip Hose	Coupler	Thread Size
81725	5818/18"	5845	1/8" NPT(m)
81726	5812/12"	5845	1/8" NPT(m)
81795*	5812/12"	5845	1/8" NPT(m)

* Includes 81980 locking sleeve.

Assemblies for Button-Head Couplers with Swivel

Maximum working pressure 4000 psi. Includes 81606 swivel.

Model	Whip Hose	Coupler	Thread Size
3029	5812/12"	80933/large	1/8" NPT(m)
3034	5812/12"	81458/standard	1/8" NPT(m)

Flexible & Rigid Extension Adapter Model 5858

Maximum working pressure 5000 psi. Allows operator to switch from flexible to rigid extension with one hand. Overall length 13". 1/8" NPT(m).

WARNING

Whip Hoses Models 3029, 3034, 5812, 5818, 5861, 81725, 81726, 81795

Install as shown



Hydraulic Couplers

Model 5852

- For all hydraulic-type grease fittings.
- Small outside diameter permits easy contact with recessed fittings.
- Replaceable hardened steel jaws.
- Built-in ball check prevents leak and lubricant backup.
- Inlet 1/8" NPT(f).



Hydraulic Coupler Displays

Model 5852

One hydraulic coupler in a resealable clamshell.

Model 5852-2

Two hydraulic couplers in the same clamshell as the 5852.

Model 5852-5

Contains five couplers; reduces cost per unit.

Model 5852-54

Contains 54 couplers in a displayable box; best value.



5845

Model 5845 Heavy-Duty

- 7500 psi maximum operating pressure.
- 11/16" Hex
- Inlet 1/8" NPT

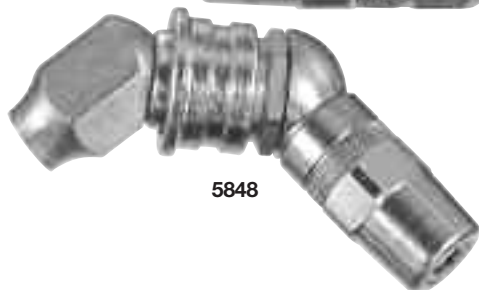

5848

Model 5848 Adapter

- 7500 psi maximum operating pressure.
- Built-in swivel allows full 360° circle.
- Locks in any one of eight 45° positions.
- Adjustable coupler section permits contact with fittings in reverse positions.
- Angle body has 1/8" NPT(f) inlet permits addition of pipe extension when required.



5883

Special Access Coupler

Model 5883 90° Grease Coupler

- Provides access to difficult to reach fittings.
- Allows for easy lubrication in tight areas.

WARNING

MATERIAL USE: Lincoln swivels are to be used only to transport grease, oil and other lubricants and are designed only for these non-abrasive and non-corrosive purposes. Do not use with abrasive and corrosive materials such as sound-deadening materials which may contain limestone and mica particles. Transport of such materials causes rapid premature wear to critical swivel components and can cause failure of swivel. Failure could expose the user to severe bodily injury, permanent disfigurement or death.

INSTALLATION & SERVICE: Tighten all fluid connections securely before using swivel. Never exceed 7500 psi maximum operating pressure. Never alter or modify any part of the swivel. Never attempt to repair or disassemble the swivel while the system is pressurized. Never stop or deflect leaks with hand or body.

MEDICAL ATTENTION: Get medical attention immediately if exposed to high-pressure fluids. Tell the attending physician what was injected.



80933



81458



10536

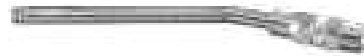

5834



62028



*5859



*5855



*81980



*5849



5803



*82784



*83278



*5884



58000

Button-Head Couplers & Adapters

Model 80933

4000 psi maximum operating pressure. For pull-on, push-on or hook-on service. Use with large 7/8" diameter button-head fittings. 7/16"-27 (f) thread.

Model 81458

Same as 80933 except for 5/8" diameter button-head fittings.

Model 10460

5000 psi maximum operating pressure. For adapting standard or large button-head couplers to hose with 1/8" NPT connections. 1/8" NPT(f) x 7/16"-27 (m) thread. Use gasket 31138, not included.

Model 10536

4500 psi maximum operating pressure. For adapting standard or large button-head couplers to hose with 3/8" NPT connections. 3/8" NPT(f) x 7/16"-27 (m) thread. Use gasket 31138, not included.

Coupler Extensions

Model 5834

7500 psi maximum operating pressure. Includes 5845 coupler and 62028 6" extension tube. 1/8" NPT(m) connection.

Rigid Extensions

Model 62028

6" length. Tough, heavy-wall seamless steel tubing. 1/8" NPT(m) at each end.

Model 62061

Same as 62028 except 12" length.

Model 62117

Same as 62028 except 18" length.

Model 5884*

Contains the 5883 90° grease coupler plus a quick-connect coupler for fast access to hard-to-reach lube points.

Extensions Adapters

Model 5859 Angle*

- 90° angle solves problem of contacting so-called "inaccessible" grease fittings.
- Design eliminates need to remove from "deep dish" wheels for lubrication of the tie rod ends and ball joints.
- Use to service cars, truck, machines and farm equipment.

Model 5855 Recessed*

Straight extension. Use to lubricate recessed fittings where obstructions will not permit use of hydraulic coupler. Includes extension nozzle and locking sleeve.

Model 81980 Locking Sleeve*

For adapting any 1/8" NPT(m) extension nozzle to a hydraulic coupler.

Model 5849 360 Degree*

7500 psi maximum operating pressure. Includes 5848 360° coupler for full swivel, 2" steel extension tube and locking sleeve.

Needle Nozzles

Model 5803

Allows operator to contact flush type or hard-to-reach hydraulic type fittings.

Model 5806

Same as 5803 except 6" length.

Model 82784*

Same as 5803 except with extension and locking sleeve.

Model 83278*

Use to lubricate U-joints and spindles. Attaches to hydraulic coupler of control valve or grease gun. Includes rubber tip.

Extension Kit

Model 58000

Heavy-duty lube accessory kit contains quick-connect versions of seven of Lincoln's most popular lube accessories. Use with all standard grease guns and dispensing devices.

WARNING

Never point needle nozzles, adapters or coupler at any part of the body or another person.

* With quick-connect locking sleeve.



Packaged Fittings—U.S. Threads

All the most popular fittings and sizes

Model 5468 Mini

Ten assorted grease fittings in three popular sizes, blister packed on one card.

Assortment Contents

Quantity	Description
6	1/4"-28 straight
2	1/4"-28 45°
2	1/4"-28 90°

5184



5470



Model 5470 Economy

24 assorted grease fittings in six popular sizes blister packed on one card.

Assortment Contents

Quantity	Description
6	1/8" NPT straight
6	1/4"-28 straight, short thread
3	1/8" NPT 45° angle
3	1/4"-28 45° angle, short thread
3	1/8" NPT 90° angle
3	1/4"-28 90° angle, short thread

5470

Model 5469 Deluxe

100 assorted grease fittings in six popular sizes. Sturdy, easy to handle transparent dispenser box has labeled and illustrated compartments.

Assortment Contents

Quantity	Description
20	1/8" NPT straight
40	1/4"-28 straight, short thread
10	1/4"-28 45° angle, short thread
10	1/8" NPT 65° angle
10	1/8" NPT 90° angle
10	1/4"-28 90° angle, short thread

5469



5191

5291

1/4"-28 Taper Thread Packs Short Thread Grease

Model	Description
5191	Card of (10) straight fittings
5291	Card of (10) 45° angle fittings
5491	Card of (10) 90° angle fittings

1/8" Pipe Thread Packs Grease Fittings

Model	Description
5190	Card of (10) straight fittings
5290	Card of (10) 45° angle fittings
5490	Card of (10) 90° angle fittings

5290

5490

Packaged Fittings—Metric Threads

All the most popular fittings and sizes

Model 5184 Mini

An assortment of three of the most used 6mm sizes and configurations blister packed on one card.

Assortment Contents

Quantity	Description
6	6mm straight
2	6mm 45°
2	6mm 90°

Model 5185 Economy

30 grease fittings in three of the most popular 6mm metric sizes blister packed on one convenient card.

Assortment Contents

Quantity	Description
16	6mm straight
6	6mm 45°
8	6mm 90°

Model 5186 Deluxe

100 assorted grease fittings in all the most popular metric sizes. Sturdy, easy to handle dispenser box has labeled and illustrated compartments.

Assortment Contents

Quantity	Description
40	6mm straight
20	6mm 45°
10	6mm 90°
5	8mm straight
5	8mm 45°
5	8mm 90°
5	10mm straight
5	10mm 45°
5	10mm 90°

5186



5184



1/8" NPT

100 Pc. Box No.	Bulk No.	Description	Length
5000C	5000	Straight	21/32"
5003C	5003	Straight	11/4"
5200C	5200	45° angle	7/8"
5300C	5300	65° angle	29/32"
5400C	5400	90° angle	27/32"

1/4" NPT

100 Pc. Box No.	Bulk No.	Description	Length
5050C	5050	Straight 1/4" NPT	15/16"
5350C	5350	65° angle 1/4" NPT	15/32"

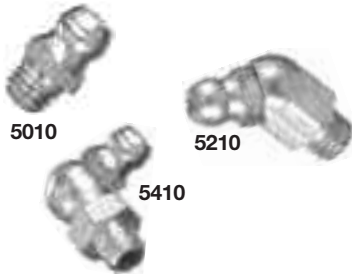

1/4"-28 SAE

100 Pc. Box No.	Bulk No.	Description	Length
5010C	5010	Straight-short thread	1/2"
5013C	5013	Straight-long thread	11/16"
5527C	5527	Straight-short thread	31/64"
5210C	5210	45° angle-short thread	7/8"
5410C	5410	90° angle-short thread	25/32"

Metric

100 Pc. Box No.	Bulk No.	Description	Length
5175C	5175	Straight	6mm
5176C	5176	45°	6mm
5177C	5177	90°	6mm
5178C	5178	Straight	8mm
5179C	5179	45°	8mm
5180C	5180	90°	8mm
5181C	5181	Straight	10mm
5182C	5182	45°	10mm
5183C	5183	90°	10mm



Button-Head

100 Pc. Box No.	Bulk No.	Description	Length
5701C	5701	1/8" NPT(m) thread	25/32"
5706C	5706	1/4" NPT(m) thread	53/64"



Drive Type

100 Pc. Box No.	Bulk No.	Description	Length	Drive Dia.
5033C	5033	Straight	9/16"	3/16"
5385C	5385	65° angle	13/16"	3/16"
—	5318	65° angle	49/64"	1/4"
5031C	5031	Straight	37/64"	5/16"



IMPORTANT ORDERING INFORMATION

To order **BULK FITTINGS**: specify exact quantity desired. Product will arrive in one package containing that quantity.

To order **100 PC. BOXED FITTINGS**: specify exact quantity of boxes desired. Product will arrive in boxes containing 100 fittings each.

Metric Thread Adapters

Convert any 1/4"-28 thread grease fitting to metric thread.

Metric Thread Adapters

Model	Thread
103307E	6mm x 1/4"-28 (f)
103308E	8mm x 1/4"-28 (f)
103309E	10mm x 1/4"-28 (f)



Fitting Bushings & Angle Bodies

Bushings & Angle Bodies

Model	Description	Length
10461	Hex bushing	1/8" NPT(f) x 1/4" NPT(m)
10787	Face bushing	1/8" NPT(f) x 1/4" NPT(m)
20028	45° angle body	1/8" NPT(f) x 1/8" NPT(m)
20029	90° angle body	1/8" NPT(f) x 1/8" NPT(m)
20026	90° angle body	1/4"-28 (m) x 1/8" NPT(f)

Easy-Out Tools

A combination tool used to remove worn or broken fittings and to retap holes for installation of new fittings. Tool has socket wrenches for removing both straight and angle fittings. May also be used to remove old pin-type fittings.

Model 66953

For tapping 1/4"-28 threads and removal of both 3/8" and 5/16" hex. straight or angle fittings.

Model 90776

For tapping 1/8" NPT threads and removal of 7/16" hex. straight or angle fittings.

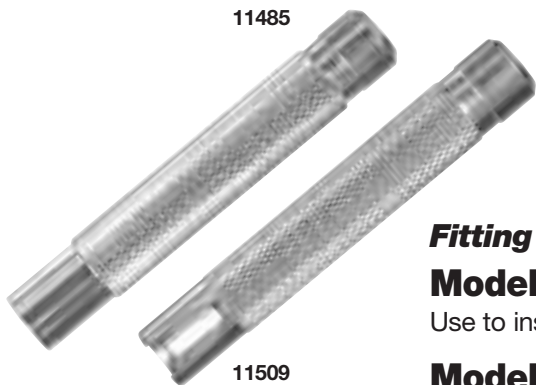

Fitting Drive Tools

Model 11485

Use to install straight Drive-Type Fittings only.

Model 11509

Use to install angle Drive-Type Fittings only.

Special Access Coupler

Model 5883 90° Grease Coupler

- Provides access to difficult-to-reach fittings.
- Allows for easy lubrication in tight areas.





224



816



102891



844



102697



102929

Lincoln Bearing Packers

Flush and pack in one operation eliminating inefficient washing and messy hand packing.

Model 224

Universal Bearing Packer forces out old grease while evenly injecting fresh grease. Pack bearing up to 4 1/2" I.D. Connects to standard grease coupler. 4.5" OD.

Model 816

Services bearings with 5/8" to 1 1/2" I.D. This versatile, compact unit mounts on work-bench or wall. Bearing is flushed and packed by contacting fitting in packer head with power gun control valve or by high-pressure hand gun. Overall dimension: 4 1/2" high, 4" wide. 3 1/4" OD.

Model 102891

Bearing packer head only; for bench mounting or attachment to any Lincoln air operated economy, Series 20 or Series 40 grease pump. Services bearings 1 3/4" to 9 1/2" O.D. with minimum I.D. of 9/16". Accepts grease through fitting from high-pressure control valve or hand gun. For bench mount use 1/2" pipe flange.

Model 844

Services bearings to 9 1/2" O.D. with minimum 9/16" I.D. Includes adapters to service bearings from 1" to 1 3/4" O.D. For use with 120 lb. original refinery container. Includes 84780 universal follower. *Specifications:* Maximum pressure 800 psi. One ounce per stroke. *Finish:* Drum cover in red enamel, pump head and handle in black. *Dimensions:* Overall height 41 7/8" with standard 120 lb. drum.

Model 102697 Super Speed Packer

Services bearings with 5/8" to 1 1/2" I.D. with up to 3 1/4" O.D. on passenger cars, light trucks and farm vehicles. Clamps securely on 25 to 50 pound original refinery container. Primes easily and pumps efficiently when using heavy greases at low temperatures. Includes flexible follower plate.

Specifications: 21" overall height, 2 1/4" wide.

Finish: Drum cover in red enamel.

Model 102929

Same as 102697 except has larger packer head to service bearing to 9 1/2" O.D. with minimum 9/16" I.D. Includes adapter to permit servicing smaller bearings of 1" to 1 3/4" O.D. Includes flexible follower plate.



Series 20 & 40 • 50:1
• Air-Operated • Double Acting
Model 917-57 120 lb. Drum

Same as 917 without roll-a-round base.

Model 346P 120 lb. Drum

Same as 917 except with 674 hand truck which provides convenient transportation for unit. Hand truck has two semi-pneumatic disc wheels and screw-type clamp which locks unit to truck. Drum not included.

Model 987 25-50 lb. Pail/60 lb. Bulk

For 25-30 lb. refinery containers or 60 lb. bulk. Gasket and air vent in lid assembly makes unit completely dust-proof, leak-proof and spill-proof. Ideal for use in all types of weather; container rust-proofed and finished in Lincoln red. Height 31³/₄"; inside diameter of container 12¹/₂".



Model 989 25-50 lb. Pail

Steel cover has three thumb screws to clamp securely to any original 25-50 lb. refinery container. Carrying handle provides easy portability. Follower plate assures positive prime at lowest temperatures. Cover rust-proofed and finished in Lincoln red. Bucket not included.



Heavy-Duty Portable Grease Pump Assemblies

Model	Bare	Drum Cover	Base	Delivery Kit*	Follower Plate	Drum Size
917	82050	46007	80895	Included	84780	120 lb.
917-57	82050	46007	NA		84780	120 lb.
346P	82050	46007	674		84780	120 lb.
987	83513	90656	NA		not supplied**	25-50 lb.
989	82716	91499	NA		84775	25-50 lb.

*Delivery kits for all units include: 75084 high-pressure hose, 11659 nipple, 740 control valve, 815 air coupler, 82399 straight swivel and 81387 universal swivel.

**Follower plate recommended to assure positive prime at lowest temperatures. Must be ordered separately.

NOTE: Free delivery 80 cu. in. per min.

Value Series 40:1 Single-Acting Grease Pumps

Features and Benefits

- Air-powered lubrication at an affordable price
- High-pressure
- Portable medium- to light-duty chassis lubrication
- Proven valved piston design
- Simple grease plunger/bushing
- Control valve and universal swivel
- Easy, one-hand operation



Model 4417 for 120 lb. Drums

Includes 40:1 value series pump, drum cover, high-pressure control valve, universal swivel, coupler, 7' connecting hose, follower plate and band dolly.

Model 4459 for 25 – 50 lb. Pail

Includes 40:1 value series pump, pail cover, handle, high-pressure control valve, universal swivel, coupler, 7' connecting hose, follower plate and band dolly.



Model 4489 for 25 – 50 lb. Pail

Same as 4459 except without band dolly.

Pump Models

	Model 4417	Model 4459	Model 4489
Container Size	120 lb.	25-50 lb.	
Four Wheel Caster Dolly	Yes		No
Delivery Kit	High-Pressure Grease Control Valve and Coupler, Universal Swivel, 7' Connecting Hose		
Ratio	40:1		
Air Motor Effective Diameter	2" / 52 mm		
Air Inlet Connection	1/4" NPTF (female)		
Lube Outlet	SAE-6 O-Ring Port		
Volume Output/Minute	5 in ³ / 82 cm ³		
Maximum Air Pressure	100 psi / 10.34 bar		
Minimum Air Pressure	40 psi / 2.75 bar		
Maximum Grease Output Pressure	6000 psi / 413 bar		
Flexible Follower	Included with all models		

Recommended Accessories

Air Line controls are a must for safe and effective pump operation.



Model No.	Description
815	1/4" Air Coupler
11659	1/4" Air Nipple
602003	1/4" Miniature Air Regulator
247843	Air Line Pressure Gauge
10462	1/4" Pipe Nipple for Regulator attachment

50:1 • Double Acting • Air-Operated

Shop/Plant/Lube Truck Applications*

Model 918 120 lb. Drum

Equipped with 82050 bare pump assembly, 46007 drum cover, 815 air coupler, 11659 air nipple, 72036 3' air connecting hose, 75060 5' high-pressure grease connecting hose, 84780 deluxe follower plate, 80202 volume elbow union. Height with drum is 39³/₈". Drum not included.

**Lube truck grease pumps: contact your Lincoln distributor.*

Model 83447 Pump Elevator Assembly

Pump elevator assembly lifts pump assembly clear of drum for easy, one person drum changes. Also helps prevent introduction of foreign material into grease during drum changes. Height with drum is 39³/₈", 67¹/₄" with elevator raised. Drum not included.

Model 926 400 lb. Drum

Equipped with 82054 bare pump assembly, 81523 drum cover, 815 air coupler, 11659 air nipple, 72036 3' air connecting hose, 75060 5' high-pressure grease connecting hose and 80202 volume elbow union. Height with drum is 46". Drum not included.

NOTE: A deluxe follower plate 83366 is recommended for use with this pump (order separately).

Model 926-1 400 lb. Drum

Same as 926 except without 81523 drum cover.

Model 1418 120 lb. Drum

Equipped with 84667 bare pump assembly, 46007 drum cover, 815 air coupler, 11659 air nipple 72036 3' air connecting hose, 75060 5' high-pressure grease connecting hose, 84780 deluxe follower plate and 80202 volume elbow union. Height with 120 lb. drum is 41³/₈". Drum not included.

Model 1426 400 lb. Drum

Equipped with 84668 bare pump assembly, 81523 drum cover, 815 air coupler, 11659 air nipple, 72036 3' air connecting hose, 75060 5' high-pressure grease connecting hose and 80202 volume elbow union. Height with 400 lb. drum is 48". Drum not included.

NOTE: A deluxe follower plate 83366 is recommended for use with this pump (order separately).

Model 1426-1 400 lb. Drum

Same as 1426 except without 81523 drum cover.

Model 2740 400 lb. Inductor

Equipped with 84668 bare pump assembly, 274681 primer assembly with follower, air powered hoist, 815 air coupler, 11659 nipple, 274728 7' air hose, 75084 7' grease hose, 602003 air regulator for hoist, and 274843 air gauge. Raised height is 97".



918



83447



926



1418

Grease Pumps

Model	Description	Bare Pump	Free Delivery (per min.)	Ratio	Drum Size	Air Inlet NPT	Material Outlet NPT
918	Shop/garage	82050	80 cu. in.	50:1	120 lb.	1/4" (f)	1/4" (f)
926	Shop/garage	82054	80 cu. in.	50:1	400 lb.	1/4" (f)	1/4" (f)
1418	High-volume shop	84667	90 cu. in.	50:1	120 lb.	1/4" (f)	1/4" (f)
1426	High-volume shop	55	90 cu. in.	50:1	400 lb.	1/4" (f)	1/4" (f)
2740	Pump with inductor	84668	90 cu. in.	50:1	400 lb.	1/4" (f)	1/4" (f)



46007

Drum Covers **Model 46007**

Drum cover for 120 lb. or 16-gallon open-top refinery containers for all series 20, 25 and 40 pumps.



81523

Model 81523

Drum cover for 400 lb. or 55-gallon open-top refinery containers for all series 20, 25 and 40 pumps.



84191

Follower Plates

Recommended when pumping lubricants that will not seek their own level.

Model 84775

Deluxe universal follower for use with 25-50 lb. containers for 1", 1 1/4", 1 1/2" diameter pump tubes. All rubber unit ensures complete grease dispensing to the bottom of dented or plastic lined drums; wipes pail or drum clean. Metal cap holds insert firmly in place, ensuring seal and maintaining vacuum.



84941

Model 84780

Same as 84775 except for use with 120 lb. containers for 1", 1 1/4", 2 1/8" diameter pump tubes. Used with Series 20 and 40 air-operated grease pumps.



84377

Model 83366

Deluxe pressed steel follower plate for 400 lb. drums includes a seal in the hub to prevent channeling of grease past the pump tube.



80895

Drum Dollies

Model 84191 25-50 lb. Band Dolly

Band-type dolly for any original 25-50 lb. refinery containers; caster 66060.

Model 84192 120 lb. Band Dolly

Band-type dolly for use with 120 lb. refinery containers; caster 66060.

Model 84377 Drum Dolly

Use with any 400 lb. drum. ID 23 1/4", height 51 1/4", hard rubber wheels: 1" wide, 2 1/2" dia.; capacity 650 lbs.



66060

Model 674 Hand Truck

All steel, rugged construction with 6" dia. wheels. Finished in Lincoln red. 41" high x 15" wide. For use with an 120 lb. or 16-gallon drum.



674

Model 80895 Roll-A-Round Base

Use with 120 lb. refinery containers. Four ball bearing swivel casters and screw clamps.



80202

Accessories

Model 66060 2 1/2" Caster

Standard equipment on Lincoln drum and band dollies.

Model 84941

Eye bolt kit for all series 20, 25 and 40 pumps, makes drum changing easy. Two part kit screws directly onto pump for lifting with pump elevator.



83366

Model 80202 Volume Elbow

For use in stationary installations with high-pressure Lubriguns. 1/4" NPT(m) inlet; 1/4" NPT(f) outlet.



84775



PowerMaster Pump Features

- Gives years of dependable trouble-free operation.
- Costs much less to operate—costs much less to maintain.
- High-volume output—air motor has extra-long stroke for powerful, uniform delivery on both up and down strokes.
- Shovel-type pump tube used to add mechanical priming to normal suction when needed.
- Sturdy construction—plunger and bushing of sapphire-hard nitriding steel for longer life, greater wear resistance.
- Plunger, bushing and air valve mating parts are micro-lapped to close tolerances. Prevents by-passing of lubricant and bleeding of air. Eliminates need to replace washers and packings.
- Simplified maintenance. Modular design of pump tube allows for easy disassembly. Air motor piston and cylinder...no oiling required, minimum friction, no leather cups.



81538



81412



83369

Accessories

Drum Covers Model 81538

Standard 120 lb. drum cover for mounting PowerMaster II and III drum pumps to full open drums.

Model 81412

Standard 400 lb. drum cover for mounting PowerMaster II & III Series drum pumps on full open drums.

Follower Plates

Recommended when pumping lubricants that will not seek their own level.

Model 83369

For 400 lb. drums. Diameter 215/8".

Model 84780

For 120 lb. drums.

Air Motor Muffler

Model 66764

For use on pump stations that incorporate the PowerMaster II air motor. 3/4" NPT(m). Two required per air motor.



66764



1716

Model 1716 Pump Hoist

For use with all PowerMaster II Series 1900 pumps. Air-operated single post pump hoist for 55-gallon drums performs several functions in applications of low- to medium-viscosity materials. Facilitates drum changeovers. Includes follower and wiper which uses normal suction to help maintain pump prime.

Specifications

Model	Height		Operating Air Pressure psi / bar	Beam		Lift Capacity
	Lowered	Raised		Length	Rotation	
1716	73" / 1.9m	110 1/2" / 2.8m	40-200 / 3-14	19" / .5m	360°	400 lbs/182kg

Series 1900 PowerMaster High-Pressure Grease Pumps

Model	Ratio	Pump Tube Type	Air Motor	Diameter in. / mm	Pump Tube	Material Outlet	Output per cycle cu. in / cc	Approx. Cycles per gal / liter
1903	40:1	400 lb.	82730	4 1/4" / 108	82792	3/4" NPTF	2.8 / 46	83 / 22
1904	75:1	400 lb.	82730	4 1/4" / 108	82793	3/4" NPTF	1.6 / 26	149 / 39
1908	75:1	120 lb.	82730	4 1/4" / 108	82883	3/4" NPTF	1.6 / 26	144 / 39
1910	50:1	400 lb.	82730	4 1/4" / 108	83271	3/4" NPTF	2.3 / 38	101 / 26

Model	Gallons / Liters per Minute			Min. ID Air Supply Hose in. / mm	SCFM@70 psi	Air Consumption Per Cycle		
	30 CPM	50 CPM	70 CPM			M ³ /min.@5 bar	SCFM@100 psi	M ³ /min.@7 bar
1903	.4 / 1.4	.6 / 2.3	.8 / 3.2	1/2" / 12	.5	.014	.62	.017
1904	.2 / .8	.3 / 1.3	.5 / 1.8	1/2" / 12	.5	.014	.62	.017
1908	.2 / .8	.3 / 1.3	.5 / 1.8	1/2" / 12	.5	.014	.62	.017
1910	.3 / 1.1	.5 / 1.9	.7 / 2.6	1/2" / 12	.5	.014	.62	.017

*All PowerMaster pumps include 3/4" NPTF(m) x 1/2" NPTF(f) bushing in the material outlet.

Full range of Series II and Series III PowerMaster pumps available. See your Lincoln representative.

Manual Bucket Pumps

These quality-built Lincoln bucket pumps dispense high-pressure lubrication in any weather — even at 0°F. Select from pump units developing 2500 to 5000 psi for normal lubrication service or lubrication of trac-roll bearings.

Model 1292 Grease Pump

Unit clamps on any 25–50 lb. refinery container in 60 seconds. Includes 275184 flexible follower plate. Dimensions: 21 1/2" h. x 12 1/4" w. Tube size 1 1/4".

Model 1272

Large 30 lb. lubricant capacity with easy pumping action, develops a 3500 lb. maximum pressure to lubricate the most closely fitted bearings. Automatic pressure release prevents nozzle drippage, waste and mess. Pump and lid assembly easily removed as a single unit for filling. Order 7' hose and coupler assembly (81768) separately.

Dimensions: 28" h x 14" w x 9" dia.

NOTE: Models 1272 and 81768 make up former model 1273D.

Model 1275

All purpose pump dispenses both lubricants and greases. Especially useful for lubrication of trac-roller bearings. Handle slot pin switches for high pressure 5000 psi or low pressure 2000 psi delivery. 40 lb. capacity steel container filled through pivot cover opening in lid. May also be used for fast, clean refilling of transmissions, differentials, gear cases and final drives. Order 5' hose (79060) and coupler (80933) separately.

Dimensions: 23 1/2" h x 11 3/8" w x 14 5/8" long.

NOTE: Models 1275 and 81168 make up former model 1276.

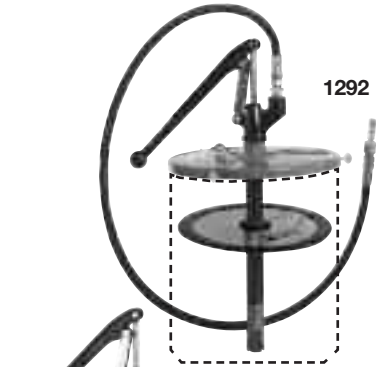

1292



1272 shown with optional hose



1275 shown with optional hose and coupler assembly

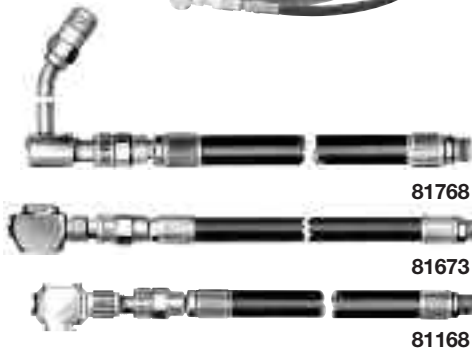

81768

81673

81168

Delivery Hose Assemblies for Bucket Pumps

2250 psi maximum operating pressure

Model	Length	Swivel	Coupler Extension
FOR CONTACTING HYDRAULIC FITTINGS			
81768	7'	80924	5834
FOR CONTACTING STANDARD BUTTON-HEAD FITTINGS			
81673	7'	80924	81458
FOR CONTACTING LARGE BUTTON-HEAD FITTINGS			
81168	7'	80924	80933

Manual Grease Pumps

Model	Cont. Size	Max. Pressure	Coupler Acces.	Hose	Follower	Output
FOR USE WITH ORIGINAL REFINERY CONTAINERS—SUPPLIED W/BUCKET COVER ASSEMBLY						
1292	25–50 lb.	2500 psi	5852	5 ft. 79060	275184	.303/stroke ¹
SELF CONTAINED MODELS						
1275	40 lb. bulk	5000 psi	80933	none	not supplied	.37 oz. stroke high ²
1272	30 lb. bulk	3500 psi	81768			.95 oz. stroke low

¹Using no. 1 multi-purpose grease at 80°F

²Using no. 1 cup grease at 70°F

WARNING

For safe and proper use, always consult instructions accompanying product. See **Safety Warning Information** for appropriate warnings.

Filler Pumps—Portable & Stationary

- Fast (less than a minute), positive gun refilling with simple pumping action
- Filler socket assembly eliminates mess, waste and air pockets

Model 1296 Clamp-On Carry

Clamps to any original 25-50 lb. refinery container. Handles medium and light lubricants in any weather. Includes pump, filler socket, 274790 flexible follower plate and ribbed steel drum cover. Rust resistant. Tube size 1 1/2".

Model 500L Stationary 120 lb. Drum

For use with original refinery drums with maximum head diameter of 14 9/16" and overall height of 26 5/8". Handles all high-pressure lubricants. Includes pump, filler socket and drum cover with one set of adjusting screws to accommodate variations in drum diameter. Red enamel finish; pump head and handle in black. Delivers 1 oz. per stroke.

Filler pumps

Model	Container Size	Follower Plate	Filler Socket**	Dimensions
1296	25-50 lb.	274790	274712	20"h x 12 1/4"w
500L	120 lb.	none*	80133	26 5/8"h x 14 9/16" dia.

* For pumping extra heavy lubricants, order follower plate 84780 for 500 pump.

**Requires 91108 filler nipple



1296



500L



80133

Model 80133 Filler Socket Assembly

Convert guns and pumps for fast, convenient, economical loading. For attaching to filler pumps that are not Lincoln models; 3/8" NPT(f).

Model 91108 Filler Nipple

Enables any grease gun to be loaded using a Lincoln filler pump or any filler pump with a 80133 filler socket assembly.



91108

3:1 – 5:1 • Motor Oil, ATF, Gear Lube and Other Fluid Lubricants

Now you can build your 3:1 ratio or 5:1 ratio oil pump with a stub pump plus suction kit, or you can order complete models. You make the choice.

Series 25 Pumps

This 2" diameter, 25 cubic inch displacement stub pump family is based on our 3:1 ratio 282396 bare stub pump.

Model 282398

3:1 pressure ratio stub pump assembly comes complete with 282396 bare stub pump, 84935 pump cover kit, 73024 oil connecting hose, 72024 air connecting hose, 241584 90° volume union elbow, 815 air coupler, 11659 air nipple and 84538 bung bushing. Delivers a uniform 6 gallons of product per minute free delivery. Ideal for dispensing fluids from drums, tanks or remote standpipe mount.

Series 40 Pumps

This industry proven 2 1/2" diameter, 40 cubic inch displacement stub pump family is based on the Lincoln 5:1 ratio 84933 bare stub pump.

Model 84934

5:1 pressure ratio stub pump assembly comes complete with 84933 bare stub pump, 85935 pump cover kit, 73024 oil connecting hose, 72024 air connecting hose, 241584 90° volume union elbow, 815 air coupler, 11659 air nipple and 84538 bung bushing. Delivers a uniform six gallons of product per minute free delivery.

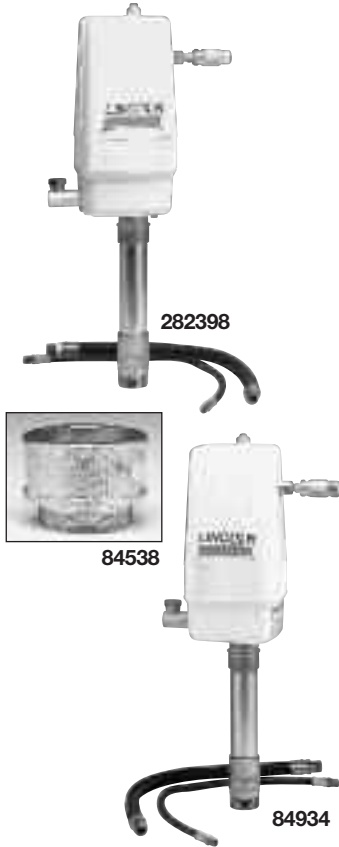

Versatile Stub Pump Mounting Options

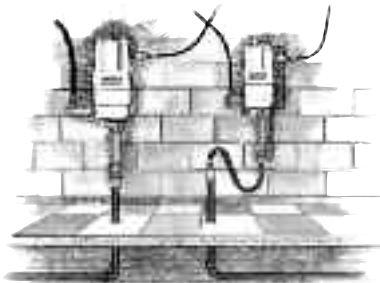

Standpipe and wall mount assembly to remote bulk tanks

3:1 (282398) or 5:1 (84934) pump, wall mount kit (84940), low level cut-off (84946) or foot valve (85765).



Wall mount to any size drum

3:1 (282398) or 5:1 (84934) pump, wall mount kit (84940), suction kit (84945) and low level cut-off (84946) or foot valve (85765).

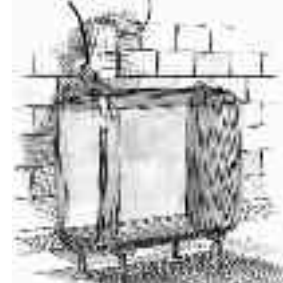

Above ground tank

(275-gallon tank shown) 3:1 (282398) or 5:1 (84934) pump and universal suction kit (85949).



55-gallon drum mount using bung bushing

3:1 (282398) or 5:1 (84934) pump and 55-gallon drum suction (85755).

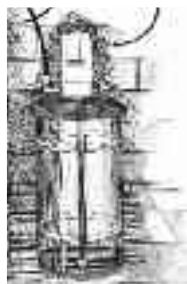

16-gallon drum mount using drum cover

3:1 (282398) or 5:1 (84934) pump, drum cover (46007) and 16-gallon drum suction kit (85716).

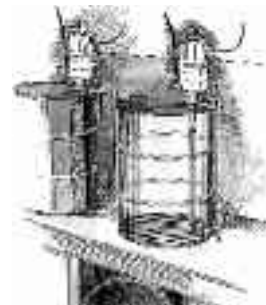

55-gallon drum mount on lube truck using drum cover

3:1 (282398) or 5:1 (84934) pump, eyebolt kit (84941), drum cover/tie-down kit and 55-gallon drum suction kit (85755).



3:1 – 5:1 • Motor Oil, ATF, Gear Lube and Other Fluid Lubricants

Shop/Garage/Lube Truck* Applications —16-Gallon Drums

Model 2437

Complete with pump, 73060 lubricant connecting hose, 241584 volume elbow, 72060 air connecting hose, 815 air coupler, 11659 air nipple.

Model 83447

Pump elevator assembly lifts pump assembly clear of drum for easy, one person drum changes. Height with drum is 39³/₈" , 67¹/₄" with elevator raised. Drum not included.

55-Gallon Drums

Model 2424

Comes complete with 282133 pump, 84538 2" NPT(m) bung bushing, to fit original 55-gallon bung opening drums, 241584 volume union elbow, 815 air coupler, 11659 air nipple, 73060 lubricant connecting hose and 72060 air hose.

250-/275-Gallon Tanks

Model 284168

Comes complete with 282396 pump and 85949 universal suction tube kit, 84538 bung bushing, air and lubricant connecting hose. Pumps oil, gear lube, ATF, etc. from tanks, drums. 285168 same as 284168 except with 84933 5:1 pump.

**For lube truck applications, contact your Lincoln distributor.*

Series 25 Oil Pumps

Note: All models based on the 282396 series 25 3:1 bare oil pump which delivers 6 gpm free flow plus a suction tube.

Model	Description	Bare Pump No.	Free Delivery	Ratio	Drum Size	Air Inlet	Material Outlet	Use/ Location
282396	Bare stub pump	282396	6 gallons	3:1	stub/universal	1/4" NPT	1/2" NPT	universal
282398	Stub pump assemb.	282396	6 gallons	3:1	stub/universal	1/4" NPT	1/2" NPT	universal
2437	Stationary	85716 & 282396	6 gallons	3:1	16-gallon	1/4" NPT	1/2" NPT	shop
282133	Bare drum pump	282396	6 gallons	3:1	55-gallon	1/4" NPT	1/2" NPT	replacement
2424	Stationary	282133	6 gallons	3:1	55-gallon	1/4" NPT	1/2" NPT	shop
284168	Stationary tank	282396	6 gallons	3:1	250-/275-gallon	1/4" NPT	1/2" NPT	shop

Series 40 Oil Pumps

All models based on the 84933 Series 40 5:1 bare oil pump which delivers 6 gpm free flow plus a suction tube.

Model	Description	Bare Pump No.	Free Delivery	Ratio	Drum Size	Air Inlet	Material Outlet	Use/ Location
84933	Bare stub pump	84933	6 gallons	5:1	stub/universal	1/4" NPT	1/2" NPT	universal
285133	Bare drum pump & tube	84933	6 gallons	5:1	55-gallon	1/4" NPT	1/2" NPT	replacement
2524	Stationary 55-gal.	285133	6 gallons	5:1	55-gallon	1/4" NPT	1/2" NPT	shop
2537	Stationary 16-gal.	85716 & 282396	6 gallons	5:1	16-gallon	1/4" NPT	1/2" NPT	shop
84934	Stub pump assemb.	84933	6 gallons	5:1	stub/universal	1/4" NPT	1/2" NPT	universal
285168	Stationary tank	84933	6 gallons	5:1	250-/275-gallon	1/4" NPT	1/2" NPT	shop
285231	Lube truck	285133	6 gallons	5:1	55-gallon	1/4" NPT	1/2" NPT	lube truck



84538



82439



84946



85765

Series 25 & 40

Bung Bushing / Low Level Cut-Off / Foot Valves

Model	Description	Threaded Connection	Notes
84538	Pump bung bushing	2" (m)	Mounts series 25 or 40 pump to 2" oil drum opening
82439	Low-level cutoff	1 1/2" NPT(m)	Used with "new oil" oil pumps
84946	Low-level cutoff	1" NPT(m)	Used with "new oil" oil pumps
85765	Foot valve	1" NPT(f)	Used with "new oil" oil pumps

Wall Mount Kit

Model	Description	Notes
84940	Wall mount kit-Series 25 & 40	Used with 84945 Suction Kit

Suction Kits

Model	Description	Threaded Connection	Notes
84945	Remote suction kit	1" NPT(f)	Includes 5' oil hose, bung bushing and 1" x 32" pipe
85716	16-gal. drum suction kit	1" NPT(m)	Adapts any series 25 or 40 oil pump to 16-gallon drum
85755	55-gal. drum suction kit	1" NPT(m)	Adapts any series 25 or 40 oil pump to 55-gallon drum
85949	Universal suction kit	1" NPT(m)	Adapts any series 25 or 40 oil pump to drum or tank use

Pump Covers

Model	Description	Notes
84935	Pump cover	Series 20 pumps
85935	Pump cover	Series 25 & 40 pumps

Hose

Model	Description	Threaded Connection	Notes
72036	3' low-pressure connecting	1/4" NPT(m)	Max working pressure: 250 psi
72060	5' low-pressure connecting	1/4" NPT(m)	Max working pressure: 250 psi
73036	3' medium-pressure connecting	1/2" NPT(m)	Max working pressure: 1000 psi
73060	5' medium-pressure connecting	1/2" NPT(m)	Max working pressure: 1000 psi

Eye Bolt Kit

Model 84941

Eye bolt kit for all series 20, 25 and 40 pumps, makes drum changing easy. Two part kit screws directly onto pump for lifting with pump elevator.

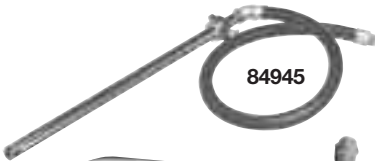

84941



85935



72036

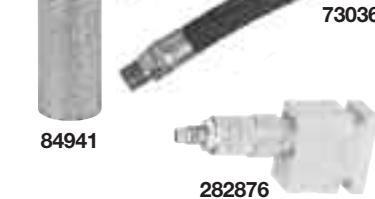

73036

84941

282876

Thermal Pressure Relief Valve

Model 282876

Protect lube system components from high-pressure spikes caused by temperature change in a closed fluid network.

Model	Application	Pre-Set Relief Pressure	Port Size
282876	Piston Pumps	1000 psi (68 bar)	1/2" NPT
282902		150 psi (10 bar)	
275197		500 psi (34 bar)	

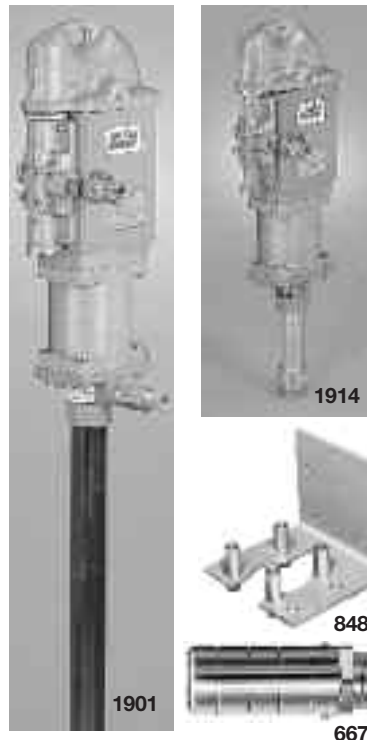

Motor Oil, ATF, Gear Lube and Other Solutions

PowerMaster Pump Features

- Gives years of dependable trouble-free operation.
- Costs much less to operate—costs much less to maintain.
- High-volume output—air motor has extra-long stroke for powerful, uniform delivery on both up and down strokes.
- Pump outlet body of all-steel construction designed to withstand pulsation and extreme pressure. All wearing parts are tough, heat-treated steel.
- Trouble-free, positive performance. Air motor operation has no springs to wear out, rust or lose tension. Air valve is stall-proof, leak-proof and pre-lubricated. Double-acting mechanisms ensure dependable low-surge operation with minimum air consumption.
- Simplified maintenance. Modular design of pump tube allows for easy disassembly. Air motor piston and cylinder...no oiling required, minimum friction, no leather cups.

Model 84826 Universal Wall Mounting Bracket

For PowerMaster II or III air motor assemblies.

Air Motor Muffler

Model 66764

For use on pump stations that incorporate the PowerMaster II air motor. 3/4" NPT(m). Two required per air motor.

Ball Type Medium-Pressure Pumps

Model	Ratio	Pump Tube Type	Air Motor	Diameter in. / mm	Pump Tube	Material Outlet**	Output per cycle cu. in / cc	Approx. Cycles per gal / liter
1901	12:1	55-gal	82730	4 1/4" / 108	82790	3/4" NPTF	9 / 148	26 / 7
1952	6:1	55-gal	82895	3" / 76	82790	3/4" NPTF	9 / 148	26 / 7

Medium-Pressure Stub Pumps

Model	Ratio	Pump Tube Type	Air Motor	Diameter in. / mm	Pump Tube	Material Outlet**	Output per cycle cu. in / cc	Approx. Cycles per gal / liter
1914	12:1	stub	82730	4 1/4" / 108	84335	3/4" NPTF	9 / 148	26 / 7

* Not to be used with meters. ** All PowerMaster pumps include 3/4" NPTF(m) x 1/2" NPTF(f) bushing in the material outlet.

NOTE: Model number with "-1" indicates model including bung bushing (ex., 1935-1).

Model number with "-2" indicates model including drum cover (ex., 1935-2).

Full range of Series II and Series III PowerMaster pumps available. See your Lincoln representative.



Model 83132 Bung Bushing

Screws in bung opening of 400 lb. drums and custom-built tanks to secure any PM II & III pumps. Plated to resist rust. Threaded 2" NPT(m).

Model 84945 Suction Kit

For transfer of product from drums, bulk tanks or reservoirs. Includes bung bushing suction tube, hose and coupling assembly. NOTE: 2" x 1" bell reducer required for use with Model 1914, not included.

Model 82439 Low-Level Cutoff

Automatically shuts off flow of oil; keeps supply lines primed. Recommended when dispensing oil through metering devices to conform with standards of the National Conference of Weights and Measures. Assembles to 1 1/2" NPT standpipe which assembles to pump.

Model 84946 Low-Level Cutoff

Same as 82439, except 1" NPT.

Thermal Pressure Relief Valve Model 282876

Protect lube system components from high-pressure spikes caused by temperature change in a closed fluid network.

Model	Application	Pre-Set Relief Pressure	Port Size
282876	Piston Pumps	1000 psi (68 bar)	1/2" NPT

Medium-Pressure • Gear Lube and ATF

Air-Operated Mobile Gear Lube Dispensers

Fast, clean refilling using efficient Lincoln air-operated pumps.

- 3:1 (2435) and 5:1 (2535) pump ratios delivers gear oil with minimum consumption.
- Air expeller built into pump tube prevents air from registering through meter.
- Large replaceable swivel casters provide ease of maneuverability (mobile models).
- Baked on enamel finish retards rust and corrosion.
- Includes air coupler 815 and 780 shut-off valves. Drum not included.



2535

Manual Gear Lube Dispensers

These quality manually-operated pumps provide fast, clean refilling of differentials, gear cases and final drives.

- Cast iron pump outlet body and handle (except 1293) provide durability and longevity.
- Metered models have air expeller built into pump tube (prevents air from registering on meter).
- Large replaceable swivel casters provide ease of maneuverability (mobile models).
- Baked enamel finish helps prevent rust and corrosion.
- Self-contained units and sealed models prevent contamination or spillage of product being dispensed.
- Smooth, easy pumping action (no crank or gears) dispenses all types of gear lubricants, even in the coldest weather.



535

ATF Dispensers

Provides fast, clean refilling of all types of transmissions. Ideal for passenger vehicles, light trucks and vans.

- Cast iron pump outlet body and handle provide durability and longevity.
- Air expeller built into pump tube prevents air from registering through meter.
- Large replaceable swivel casters provide ease of maneuverability (mobile models).
- Baked-on enamel finish retards rust and corrosion.
- Smooth, easy pumping action for positive fluid dispensing, even in the coldest weather.



Note:
Specifications
on page 25.

1253

WARNING

For safe and proper use of pumps, always consult instructions accompanying product. See **Safety Warning Information** for appropriate warnings.



1254



1293

82757



527

Air-Operated Mobile Gear Lube Dispensers

Model	Container	Meters	Style	Base	Hose Length	Pump Tube	Nozzle	Output
2435	120 lb.	pint	Drum cover	80895 roll-a-round	5 ft. (73060)	25 ³ / ₄ "	780	6 gpm
2535	120 lb.	pint	Drum cover	80895 roll-a-round	5 ft. (73060)	25 ³ / ₄ "	780	6 gpm
2435LN	120 lb.	liter	Drum cover	80895 roll-a-round	5 ft. (73060)	25 ³ / ₄ "	780	6 gpm

Manual Gear Lube Dispensers

535	120 lb.	pints	15" ID drum cover	80895 roll-a-round	5 ft. (74560)	25 ³ / ₄ "	80599	*
535LN	120 lb.	liters	15" ID drum cover	80895 roll-a-round	5 ft. (74560)	25 ³ / ₄ "	80599	*
535-58	120 lb.	pints	15" ID drum cover	none	5 ft. (74560)	25 ³ / ₄ "	80599	*
549	120 lb.	none	15" ID drum cover	80895 roll-a-round	5 ft. (74560)	25 ³ / ₄ "	80599	*
549-58	120 lb.	none	15" ID drum cover	none	5 ft. (74560)	25 ³ / ₄ "	80599	*
1253	30 lb. bulk	pints	self cont. handle	Int. 9" dia / 13 ³ / ₄ "w	5 ft. (74560)	17" below rim	80599	*
1253LN	30 lb. bulk	liters	self cont. handle	Int. 9" dia / 13 ³ / ₄ "w	5 ft. (74560)	17" below rim	80599	*
1254	30 lb. bulk	none	self cont. handle	Int. 9" dia / 13 ³ / ₄ "w	5 ft. (74560)	13" below rim	80599	*
1293	30 lb. bulk	none	12" ID clamp-on carry	none	5 ft.	13" below rim	NA	**

Model 82757 Hose/Nozzle Kit

Hose and nozzle upgrade kit for model 1293. Includes 80999 nozzle assembly and 5' 74560 hose. Order separately.

ATF Dispensers

527	120 lb.	none	15" ID drum cover	80895 roll-a-round	7 ft.	25 ³ / ₄ " below rim	93547	***
527A	120 lb.	quarts	15" ID drum cover	80895 roll-a-round	7 ft.	25 ³ / ₄ " below rim	93547	***

* 1 pt. per 7 strokes using SAE 90 Gear Lubricator at 70°F

** 1 oz. per stroke using SAE 90 at 70°F

*** 8 strokes per quart



Drum Transporters

Model 674 Hand Truck

All steel, rugged construction with 6" dia. wheels. Finished in Lincoln red. 41" high x 15" wide. For use with an 120 lb. or 16-gallon drum.

Model 80895 Roll-A-Round Base

Use with 120 lb. refinery containers. Four ball bearing swivel casters and screw clamps.

Drum Dollies

Model 84191 25-50 lb. Band Dolly

Band-type dolly for any original 25-50 lb. refinery containers.

Model 84192 120 lb. Band Dolly

Band-type dolly for use with 120 lb. refinery containers.

Model 84377 Drum Dolly

Use with any 400 lb. drum. ID 23¹/₄", height 5¹/₄", hard rubber wheels: 1" wide, 2¹/₂" dia.



80895



84191



84377



4262

3:1 and 5:1 Ratio Pump Packages

Lincoln pump 3:1 and 5:1 ratio packages include 600003 regulator, 600401 gauge, 815 coupler and 11659 nipple. Control valve, inline meter or hand-held metering control valve must be ordered separately (except model 4283).

Model 4265 3:1 with 30' Reel

3:1 ratio bulk oil pump with 2" bung bushing 282398 and model 85949 universal suction tube with foot valve for drum or tank mounting. Includes 1/2" x 30' oil reel with 2' connecting hose 87334/94334.

Model 4262 3:1 with 50' Reel

3:1 ratio pump with 2" bung bushing 282398 and model 85949 universal suction tube with foot valve for drum or tank mounting. Includes 1/2" x 50' oil hose reel with 2' connecting hose 87354/94354.



4283

Model 4283 5:1 with 50' Reel & Meter

Deluxe assembly including 84934 5:1 ratio pump with bung bushing, universal suction tube with foot valve to fit any size container up to 275 gallons. Includes 1/2" x 50' oil hose reel 87354/94354 with 2' connecting hose. 967 electronic meter totalizes in gallons with quart, gallon or pint readout.

NOTE: Pipe, fittings and hardware for installation of overhead reel assembly supplied by others.

Reel • Pump • Meter Packages

Lincoln puts all the components you specify in one easy-to-order package.

RPM Packages

Model	Pump Kit/Ratio	Reel/30'	Electronic Meter	Air Regulator	Air Gauge
RPM 8	282398/3:1	87334	954 universal	600003	600401
RPM 10	84934/5:1	87334	954 universal	600003	600401

NOTE: Always consult fluid/solution manufacturer specifications AND local fire code(s) before installing any pump into service. Most modern automotive fluid/solutions include some type of "additive package" which may not be compatible with the typical applications listed below. Some fluids or solutions are considered flammable and/or combustible in which case the dispensing pump should be properly grounded. (Order air coupler and air nipple separately)



4493 System for mounting pump and reel on tank

Model 4493 Value Series Pump, Reel and Meter Package

- Configured for above ground tank installations.
- For use with natural and synthetic oils, automatic transmission fluid, gear oil, antifreeze or hydraulic oil throughout the shop.
- Fast, reliable dispensing with the 4491/six GPM free delivery pump.
- Easy handling, dependable service with the 94000 Series hose reel's heavy-gauge steel base, brass bushings and extra-wide hose guide.
- Accurate and easy dispensing with the 952 electronic oval gear meter with flexible extension.
- Package includes 4491/3.5:1 pump, 94334 reel with 30' x 1/2" hose, ball stop, 952 electronic meter (measures in quarts), air line regulator and gauge, air coupler and nipple, 2' fluid connecting hose from pump to reel and adapter union.

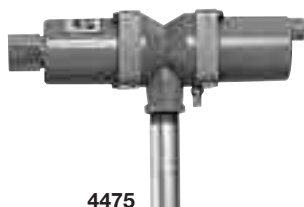

4475



4480

Features and Benefits—Designed for Value

- Proven horizontal, valved-piston motor design for simplicity and reliability
- Provides quick dispense, fill or transfer with high-volume output
- Built-in muffler for quiet operation
- Cost-effective solution for oil distributors who need to supply pumps for customers who purchase bulk oil in tanks or drums
- Available as stub pump, 16-/55-gallon pump or 250-275 tank pump
- Motor's single-stroke action delivers cost effective, high performance and high flow
- Provides quick dispense and fill of ATF, oil, gear lube and other fluid lubricants with the speed of many higher-priced pumps
- Ideal for use with one or two overhead reels in applications such as medium to light vehicle service facilities, car dealerships, small contractors, farmers and agriculture equipment dealers

Specifications

Pump Ratio	Output/Stroke	Delivery Output	Pneumatic Inlet Pressure		Oper. Temp. Range	Weight (Empty)	Pneum. Port Inlet	Material Port Outlet	Rec'd. Fluids
			Max.	Min.					
3.5:1	5.6 in ³ 91 cm ³	6 GPM	120 psig 8.3 bar	20 psig 1.4 bar	30°F - 120°F -1°C - 49°C	14 lbs.	1/4-18 NPTF	1/2 NPTF	Motor oils, transmission fluid, petroleum-based fluids

Not for water-based products

Pump Models

Model No.	Application	Mounting	Down Tube Length
4490	55-gallon	2" NPT male bung adapter	36.5"
4491	250-275-gallon oval tank	2" NPT male bung adapter	47.0"
4492	Stub	1.5" NPT male	N/A

Model 4475 Series Pump

The Model 4475 pump is a reciprocating-piston, low-pressure single action pump. Air powers the pump's piston on the dispensing, or working, stroke. An internal spring returns the piston and resets it for the working stroke. It pumps continuously when the dispensing (fluid outlet) valve is open and 20-120 psig air is supplied to the pump.

Specifications

Model	Description	Material Outlet	Operation	Pump Tube Length	Attachment	Effective Pump Ratio	Inlet Air Pressure	Output/Stroke	Free Delivery
*4475	Bare Pump	1/2" NPTF	Pneum. pressure delivery stroke, spring return stroke	34" (86 cm)	2" Bung, adj. for 55- & 16-gal. drums, bench & portable tank	Approx. 0.7:1 to 0.8:1 depending on inlet air pressure	Max: 120 psi (8.3 bar) Min: 20 psig (1.4 bar)	2.9 in ³ (48 cm ³)	Up to 4 gpm (15 lpm)
*4480	Spigot Pump	Spigot extension with on/off valve							

* Bung bushing 261102, 261103, 261104



1:1 Piston Transfer Pumps

Model	Pump Descrip.	Pump Body	Wetted or Soft Parts	Pump Inlet/Outlet NPT	Max. Free Delivery GPM	Air Inlet NPT(f)	Max. Rec. Inlet Air Pressure	Max. Susp. Solids Dia.	Typical Automotive Use
84829	stub	alum/steel/plastic	Buna-N	1" / 3/4"	14 gpm	1/4"	150 psi	NA	Universal/ new oil transfer
82230	55 gal. drum	alum/steel	Buna-N	3/4" – 1 1/2" A.N.	20 gpm	1/8"	150 psi	NA	55 gal. drum/ new oil transfer

Model 84829 Universal

Stub pump design provides the versatility to transfer and dispense controlled amounts of lubricant using an oil spigot, control valve or meter. Adaptable for 16- or 55-gal. containers as well as bulk tank or standpipe installations. Delivers 12.5 cu. in. per cycle. Includes suction tube, bung bushing, air coupler and air nipple. Includes 241937 extension tube.

Model 82230

Transfer pump quickly transfers fluids directly from 55-gallon drums. 2" bung bushing adjusts to varied drum lengths. Designed to stall against lubricant pressure. Empties a 55-gallon drum in less than three minutes and has adjustable air flow lever.

82230



84829



1326

Model 1326 Diaphragm Action

Neoprene seals resist wear from abrasive fluids. Double acting diaphragm delivers one full gallon per eight strokes. 8' hose with discharge nozzle.

Transfer Pump

Model	Drum Size	Bung Bushing	Output
1326	16 to 55 gal. w/2" bung opening	2" NPT(m)	1 pint per stroke

Model 1335

This close tolerance pump utilizes brass rings for extreme durability and expanded fluid compatibility. Telescoping pick-up tube for 16- through 55-gallon drums with standard 2" bung openings. Bung opening tool built into pump head to open sealed refinery container. Provides 8.5 fl. oz. per full stroke. For use with non-corrosive fluids such as motor oil, transmission fluid, gear oil, engine coolant, silicone oils, laquer thinner, brake fluid and more.



1335

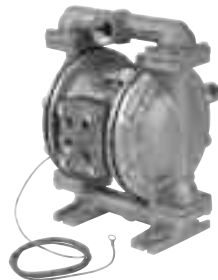

85634

1:1 Air-Operated Diaphragm Pump Line

Model Number	Pump Desc.	Pump Body	Wetted or Soft Parts	Pump Inlet/Outlet NPT	Max. Free Delivery gpm	Air Inlet NPT(F)	Max. Rec. Inlet Air Pressure	Max. Susp. Solids	Application
85632	1/2"	Aluminum	Teflon	1/2" / 1/2"	15	1/4"	100 psi	1/8"	New Oil, AF
85627	1"	Aluminum	Buna-N	1" / 1"	45	1/2"	125 psi	1/4"	New/Used Oil, AF

* Can be converted to dual 1/2" outlet. ** 85639 requires 275631 Adapter and 275632 Seal Kit for Pipe Thread installations

U.L. Listed

85634	1" UL	Aluminum	Buna-N	1" / 1"	45	1/2"	50 psi *	1/4"	Used oil, diesel, kerosene
-------	-------	----------	--------	---------	----	------	----------	------	----------------------------

* 50 psi flammable liquids, 125 psi others.

Choose the fluid handling equipment that fits your needs.

Traditional Drain: the traditional method for handling used fluids allows gravity to drain fluids from vehicle(s) into a portable or mobile fluid drain and then gravity allowing those fluids to drain into a used fluid storage tank.

Drain & Evacuate: instead of gravity draining fluids into a storage tank, fluids are evacuated from the fluid drain into the tank with a suction pump system.



613

Standard Oil Drains

Model 613

Used with 16-gallon (120 lb.) open-top drum (66493 drum not included). Convenient float gauge shows when drum is full. Includes 17" square rolling base 80895 with 21/2" ball bearing caster wheels and 14" drain bowl 91197 (without lid).

Order suction pick-up tube and fluid nipple Kit 247748 for easy evacuation through drum cover using a used-oil evacuation pump. Order evacuation pump 4100 and fluid coupler 244390 separately.



Model 66493 120 lb. Drum

16-gallon (120 lb.) drum with 3/4" NPT(f) threaded hole near bottom/side of drum for drain valve or spigot (70526 – sold separately.)

Pedestal-Style Oil Drain

Model 3605

Lightweight, easy to position and maneuver. Latch trigger automatically locks drain bowl at any height. Reversible for double life! Bowl cover lid hinged for splash guard extends to catch oil flowing from hard to reach drain plugs. Spring actuated valve in drain bowl to prevent leakage. Includes 82460 drain adapter bushing for draining bowl. Includes large 13 1/2", 4 1/2-gallon bowl assembly 83386.



66493

3605

Model 82460 Drain Adapter

Used with 3605 to drain bowl. When bowl is set into drain adapter bushing a pin automatically releases spring loaded valve. Adapter bushing assembles to a 2" NPT used oil tank stand pipe or screws directly into a 2" 55-gallon drum opening.

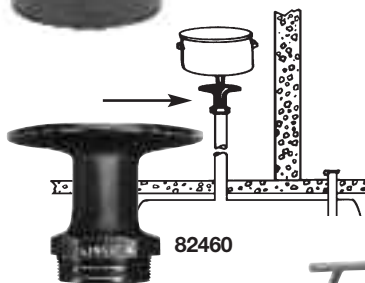

82460

Truck Oil Drain

Model 84714 20 Gallon Cart

Ideal oil drain for RV, truck, heavy equipment maintenance and repair. Low profile, large 20-gallon capacity cart. 42" T-handle for easy cart positioning. Used oil transfer by either gravity or suction evacuation. Order drain valve or suction evacuation pump and fluid couplings separately. Two stationary rear wheels and one front wheel caster with grab handle for ease of under vehicle positioning. Metal grating, two baffles and continuous side splash guards to prevent oil spillage during vehicle draining and cart movement. Maximum height is 8.65".



84714



3608

Drain Bowls

Model 3608

Large 20" bowl used on 3643 or to update an existing 3613 to a 20" drain bowl.



82786

Model 3609

Large 20" bowl used on 3644 or to update an existing 613 to a 20" drain bowl.

Model 91197

Standard 14" bowl used on 613 and 3613 used oil drains.

Model 82786

Same as 91197 but includes lid.



83386

Model 83386

Standard 13 1/2" bowl used on 3605 used oil drains. Large 4 1/2-gallon capacity.



3610

Funnel & Drain Adapters

Model 3610

24 1/2" diameter. Use when larger draining area is required. 3610 molded plastic drain pan rests securely on top of used oil drains. Can be used with pedestal or portable drain devices with 6" or larger drain

Model 275296

Funnel assembly for use with 3614.

Model 70526 Drain Spigot

Used fluid drain valve for use with 613. 1/2" NPT(m) connection.



275296

Suction Guns

Model 615

Holds up to 18 ounces of fluid. Flexible nozzle for transmission, differential or oil filter service. Precision follower fitted to barrel for superior suction and is impervious to oil, grease and water. Finished in rust-resistant, powder coated blue paint.



615

Handling / Recovery / Accessories

Drain & Pressurize: this new concept in used fluid handling employs the benefits of the drain & evacuate system without an evacuation pump—the fluid drain is pressurized to evacuate the used fluid.



Pressurized Evacuation Drains **Model 3624 26-Gallon Tank**

Pressurized, waste oil tank and bowl made from high-strength polyethylene—no dents or corrosion. Construction material reduces chance of vehicle damage if inadvertent contact is made with vehicle. Built-in oil filter drain, tool tray and sight gauge. Very stable and easy to maneuver. Includes pop-off valve and fixed air regulator for safety. Compatible with all lubrication fluids.

Model 3614 20-Gallon Tank

The model 3614 simplifies the used fluid evacuation process by allowing the technician to drain, transfer and evacuate used oils with virtually no chance of spillage. Extra large 18-inch offset bowl easily catches fluid without repositioning the tank. Telescopic (44 to 72 inch range) bowl height adjustment allows for greater flexibility. Low profile design is extremely stable and easy to maneuver. Large 20-Gallon (75 L) capacity averages 15-20 vehicles before tank evacuation. Special valve design allows evacuation with bowl set at any height.



Closed-Loop Pressurized Evacuation Drains

Drain & Pressurize (Closed-loop): the newest Lincoln used fluid handling concept takes the standard drain and pressurized system to a new level by eliminating used fluid spills while evacuating the mobile drain unit.

Model 4106 Evacuation Hose Kit

Use with 3633 to evacuate used fluid receiver. Includes 3/4" fluid coupler and 5' hose. Attaches to bulk used fluid tank for a closed-loop system.



Model 3601 - Value Series Pressurized Used Oil Receiver

The tank is constructed of an all-steel design with reinforced caster supports for durability and dependability. 14-inch telescoping bowl adjusts from 45 inches to 72 inches. Preset regulator accepts standard shop air up to 150 psi for dispensing of used fluids. 18-gallon (68 liter) fluid capacity.

Evacuation Coupler & Nipple Kit **Model 237105 Suction Hose**

For use in high-volume transfer and evacuation systems, 1" NPT(m) threads x 7'.

Fluid Couplers & Nipples

Model 241408 Coupler & Model 241409 Nipple

For use in high-volume transfer applications, both models have 1" NPT(f) thread



Fluid Evacuators

These portable units are designed for convenient evacuation of fluids from virtually any type of reservoir or tank. With capacities ranging from 1.9 quarts (1.8 liters) up to 2.3 gallons (8.8 liters), they are perfect for draining coolants from machinery, or for use when changing fluids (oil, lubricants, hydraulic fluids, etc.) on motorized equipment.

Model 07300 Pneumatovac

The larger-capacity model 07300 fluid evacuator holds up to 2.3 gallons (8.8 liters) of fluid. It uses standard compressed shop-air and a powerful venturi vacuum to quickly and conveniently evacuate reservoirs with no manual effort. Comes with 07205 adapter.

Capacity: 2.3 gallons (8.8 liters)
Weight: 7.5 lbs. (3.4 kg)
Size: 25.6" (650mm) tall x 13" (330mm) wide x 9.5" (240mm) deep



Model 07400 Fluid Evacuator

The model 07400 fluid evacuator is a manually-operated unit that requires no electricity or compressed air. The unit is extremely lightweight, and features durable, chemical resistant construction, a large stable base and three evacuation tubes with adapters.

Capacity: 1.9 gallons (7.3 liters)
Weight: 5.5 lbs. (2.5 kg)
Size: 25" (725mm) tall x 7.5" (190mm) diameter



Model 07201 Fluid Evacuator Plus – 2-Way “In or Out”

The Fluid Evacuator Plus has a reversing valve that allows the unit to be used for evacuating or dispensing fluids. It has a large 2.3-gallon (8.8) liter reservoir and operates without electricity or compressed air. The unit features durable, chemical resistant construction, a large stable base and three evacuation tubes with adapters.

Capacity: 2.3 gallons (8.8 liters)
Weight: 10 lbs. (4.5 kg)
Size: 25.6" (650mm) tall x 13" (330mm) wide x 9.5" (240mm) deep



Model 07205 Brake Bleeding Adapter

Can be used with all three fluid evacuators listed above.



Don't waste valuable time waiting on gravity to empty waste oil drains. Lincoln installed systems provide the fast, profitable, safe way to get rid of waste oils and other fluids when gravity draining is not possible or practical. Quickly pump out fluids from rolling drain pans, portable oil drains, differentials and transaxles.

Basic Fluid Evacuation Pumping System

Lincoln's Basic Fluid Evacuation and Disposal System features a 1" U.L. Listed corrosion-resistant aluminum double-diaphragm pump that creates a powerful suction to drain used fluids quickly, and transfers them through a completely enclosed system to any type of remote storage tank. Provides clean, safe disposal of waste fluids with no drips, no spills. Pump is air-operated and can be easily mounted on any convenient wall surface. One basic system can serve multiple bays with the addition of hardware.



4100

Model 4100

Includes rugged, heavy-duty, 1" U.L. Listed air-operated, double diaphragm, self-priming pump 85634, 1" x 5' fluid hose 237105, 3' air hose 72036, airline filter 602104, lubricator 602204, regulator 602004, 3/4" x 5' fluid inlet hose 68620 and other air couplings for easy outlet installation.



4105

Model 4105 Portable Drain Adapter Kit

Includes 1" x 7' suction hose 237105, quick-disconnect coupler 241408, nipple 241409 and mounting hardware for hookup to side port of 16-gal. drum 66493 or truck oil drain 84714.

Model 4110 Differential & Transaxle Kit

Includes suction hose, fittings and two interchangeable wands for all vehicle makes and models that allow you to drain fluids through plug openings.



4110

Model 84700 Rolling Drain Pan

Designed for pit installation, 30-gallon capacity 84700 features quarter-turn ball valve drain on front or back of unit for multiple drain hook-up 1 1/2" NPT. Infinite-adjustable axles fits pits 36" to 49 1/2" wide. Polyurethane wheels for smooth, quiet operation, dust cap, chain and splash guard assemblies included.



84700

Model 92572 Splash Guard Assembly

Included with 84700 drain pan. Mounts to either side to deflect oil from side draining engine oil pans.

Model 85255 Wall Mount Bracket

Wall mount bracket for 1/4" to 1/2" air-operated diaphragm pumps

Model 84817 Wall Mount Bracket

Wall mount bracket for 1/2" to 2" air-operated diaphragm pumps

Used Fluid Overfill Warning Valves

Float rises with used fluid to activate "whistle" warning at prescribed level.

Model 84815 Single Wall

For single wall tanks & drums in used fluid systems and above ground tanks.

Model 84824 Double Wall

Same as 84815 except for double walled tanks and above ground tanks.

Model 84816 4-Way Valve

Four port, two position valve used in waste fluid systems. Enables one pump to pump into and out of drum or tank.



84817



84815



84816



Lincoln's Fluid Reel Series (LFR) incorporates both new and proven design features and capabilities.

- Advanced design provides consistent, repetitive performance.
- Top-of-the-line features in our most popular reel.
- Engineered for durability and reliability.
- Low-, medium- and high-pressure models available.

Features

- Low-pressure, fully-ported swivel designed to be corrosion resistant when used for air- and water-based solutions.
- Medium-pressure, fully-ported swivel provides unrestricted flow, dispensing higher volumes of fluid.
- High-pressure swivel includes quick-disconnect for easy hose attachment.
- Two hose clamps perfectly spaced to prevent the hose from locking in the fully extended position.
- Easily accessible—yet fully contained—power springs designed for optimum performance at various operating pressures.
- Dual needle bearings reduce the stress on the spring, providing smooth, balanced operation during both hose extension and retraction.
- Rounded edges on hose guide face enhances safety.
- Electroless nickel plated, corrosion-resistant, low-pressure axle prevents contamination of fluid and restriction of flow.
- Double ratchet teeth provide solid latch to lock hose in multiple usable positions.
- Mounting base accepts Lincoln No. 82206 mounting pattern and is slotted at both ends for easy installation.
- Powder coat finish creates a corrosion-resistant reel that stands up to the elements.

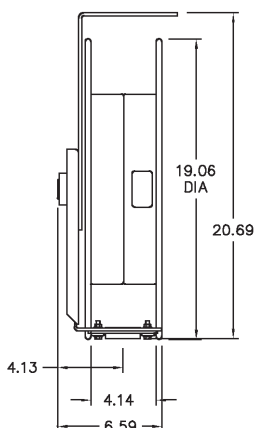
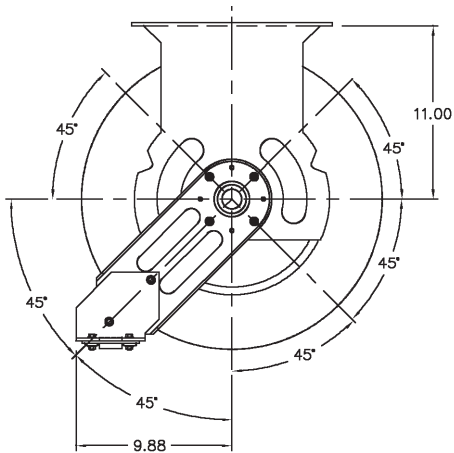

Pressure Application	Hose Diameter	Max. Working Pressure psi (bar)
High	1/4"	5,000 (340)
	3/8" & 1/2"	4,000 (272)
Medium	1/2"	1,500 (102)
Low	1/4" & 3/8"	250 (17)
	1/2"	200 (13.6)

Assembly Models: 94 5 5 2 G

Pressure	Hose Length	Hose Diameter	Valve
5 – High	5 – 50'	2 – 1/4"	G – 740
3 – Medium	3 – 30'	3 – 3/8"	H – 3050
1 – Low	6 – 60'	4 – 1/2"	A – Air Coupler/Tire W – Bibb Cock



Bare Reel Specifications

Model	Application	Rating	Hose Capacity		Max. Working Pressure Bare Reel, psi	Inlet/Outlet (f)
			Type	Max. Length		
94100	Air, A-F, Water, WW	RMA	Class A	60'	1000*	1/2" NPT
94300	Oil	SAE100R3	73	60'	2500*	1/2" NPT
94500	Grease	SAE100R2	75, 76	50'	8000*	3/8" NPT

* Note: Actual working pressure of the reel should not exceed pressure rating of the installed hose. 60' hose should be used on installations allowing for a 10' to 12' hose hand down.

High-Pressure Reels and Assemblies

Grease Reel and Hose Assemblies

Model	Bare Reel Description	Delivery Model	Connecting Hose	Hose	Included with Reel Assemblies		Ball Stop	Control Valve or Meter
					Adapter			
94532	1/4" x 30'	94500	75360	75024	10462, 10462-9, 10198		85515	NA
94552	1/4" x 50'	94500	75600	75024	10462, 10462-9, 10199		85515	NA
94553	3/8" x 50'	94500	76600B	75024	10773, 14727, 10540, 11107		85516	NA

Grease Assemblies with Universal Swivel & Control Valve

94532G	1/4" x 30'	94500	75360	75024	10462, 10462-9, 10198	85515	81387 & 740
94552G	1/4" x 50'	94500	75600	75024	10462, 10462-9, 10198	85515	81387 & 740
94553H	3/8" x 50'	94500	76600B	75024	10773, 14727, 10540, 11107	85516	81729 & 3050

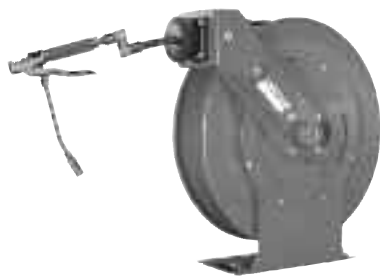

Medium-Pressure Reels and Assemblies

Oil Reel and Hose Assemblies

94334	1/2" x 30'	94300	73360	73024	11197, 12957, 12106, 10202	85517	
94354	1/2" x 50'	94300	73600	73024	11197, 12957, 12106, 10202	85517	NA
94364	1/2" x 60'	94300	73720	73024	11197, 12957, 12106, 10202	85517	

Low-Pressure Reels and Assemblies

Air, Water Reel and Hose Assemblies

94132	1/4" x 30'	94100	72360	74024	10462, 10462-9, 10198	85515	
94133	3/8" x 30'	94100	72360A	74024	10773, 14727, 10540, 11107	85516	
94152	1/4" x 50'	94100	72600	74024	10462, 10462-9, 10198	85515	
94153	3/8" x 50'	94100	72600A	74024	10773, 14727, 10540, 11107	85516	NA
94154	1/2" x 50'	94100	74600	74024	11197, 12957, 12106, 10202	85515	
94163	3/8" x 60'	94100	74720	74024	10773, 14727, 10540, 11107	85516	

Air Assemblies with Air Coupler and Tire Chuck

94132A	1/4" x 30'	94100	72360	74024	10462, 10462-9, 10198	85515	
94133A	3/8" x 30'	94100	72360A	74024	10773, 14727, 10540, 11107	85516	815
94152A	1/4" x 50'	94100	72600	74024	10462, 10462-9, 10198	85515	11659
94153A	3/8" x 50'	94100	72600A	74024	10773, 14727, 10540, 11107	85516	66951
94154A	1/2" x 50'	94100	74600	74024	11197, 12957, 12106, 10202	85517	

Water Assemblies with Water/Antifreeze Bibb Cock

94132W	1/4" x 30'	94100	72360	74024	10462, 10462-9, 10198	85515	
94133W	3/8" x 30'	94100	72360A	74024	10773, 14727, 10540, 11107	85516	
94152W	1/4" x 50'	94100	72600	74024	10462, 10462-9, 10198	85515	846 Bibb Cock
94153W	3/8" x 50'	94100	72600A	74024	10773, 14727, 10540, 11107	85516	
94154W	1/2" x 50'	94100	74600	74024	11197, 12957, 12106, 10202	85517	

Lubrication Tools and Equipment

Heavy-Duty Series Hose Reels



The Heavy-Duty Series reels are the finest Lincoln lube reels ever designed. Years of engineering, testing and experience preceded their introduction. The quality and reliability the professional expects from Lincoln is not only met but exceeded in form and function by the HD Series. Value, long-life and top performance were the criteria demanded before these incredible reels were released.



82206

Features

- All bare reels rated for high, medium and low pressure
- Reel assemblies available in standard 30', 40' and 50' hose lengths
- Dual needle roller bearings
- Ball bearing inlet swivel design
- Quick-disconnects on delivery and connecting hose
- Spring canister with seals
- Thirteen-position roller outlet arm
- Delrin rollers
- Quarter-inch thick steel welded base and roller outlet arm
- Reel sheaves are rolled
- Components individually powder painted for long life and scratch resistance
- All reel assemblies factory assembled and pressure tested to insure a quality leak-free installation every time
- Basic reel assemblies can be ordered with one model number; include delivery hose, ball stop and connecting hose
- Complete reel assemblies with meter, control valve or air coupler are also available as one model number
- Backed by a five-year limited warranty. See your Lincoln representative for details

Bare Reel Specifications

Model	Lincoln Reel Application	Hose Capacity			Working Pressure	Sheave Width	Inlet/Outlet
		SAE	Type	Length			
82206	Heavy-duty oils, chassis grease, antifreeze, ATF, air and water	100R2	75	50'	8000*	5 1/2"	1/2" NPT(f)
		100R2	76A	50'	8000*	5 1/2"	1/2" NPT(f)
		100R2	76B	50'	8000*	5 1/2"	1/2" NPT(f)
		100R3	73	50'	8000*	5 1/2"	1/2" NPT(f)
		100R1	78	50'	8000*	5 1/2"	1/2" NPT(f)
		100R6	72A	50'	8000*	5 1/2"	1/2" NPT(f)

* Note: Actual working pressure of the reel should not exceed pressure rating of the installed hose.

High-Pressure Reels & Assemblies

Basic Grease Assemblies* Less Hose End Control

Basic Reel	Bare Reel	Delivery Hose	Hose Size	Connecting Hose	Ball Stop	Control Valve
85003-30	82206	75360	30' x 1/4"	75024	85516	NA
85004	82206	75480	40' x 1/4"	75024	85516	NA
85004-50	82206	75600	50' x 1/4"	75024	85516	NA
85006-30B	82206	76360B	30' x 3/8"	76024B	85517	NA
85004-50B	82206	76600B	50' x 3/8"	76024B	85517	NA
85008-50A	82206	76600A	50' x 1/2"	76024A	85517	NA

Medium-Pressure Reels & Assemblies

Basic Fluid Lubricant, Antifreeze & WW Fluid Assemblies* Less Hose End Control

Basic Reel	Bare Reel	Delivery Hose	Hose Size	Connecting Hose	Ball Stop	Control Valve
83463	82206	73240	20' x 1/2"	73024	85517	NA
83463-30	82206	73360	30' x 1/2"	73024	85517	NA
83464	82206	73480	40' x 1/2"	73024	85517	NA
83464-50	82206	73600	50' x 1/2"	73024	85517	NA
85009-50	82206	78600	50' x 5/8"	78024	84347	NA

Low-Pressure Reels & Assemblies

Basic Air, Water* Less Hose End Control

Basic Reel	Bare Reel	Delivery Hose	Hose Size	Connecting Hose	Ball Stop	Control Valve
85232	82206	72360	30' x 1/4"	72024	85515	NA
85002	82206	72480	40' x 1/4"	72024	85515	NA
85011	82206	72600	50' x 1/4"	72024	85515	NA
85002A	82206	72480A	40' x 3/8"	72024A	85516	NA
85001	82206	72600A	50' x 3/8"	72024A	85516	NA
85005	82206	74480	40' x 1/2"	74024	85517	NA
85010-50	82206	74600	50' x 1/2"	74024	85517	NA

* See pages 37- 41 for meter, valve, or air coupler options for end of delivery hose.

Extra-Heavy-Duty Reels for Applications that Require High Product Flow and/or Longer Hose such as Service Trucks, Lube Trucks, Transit Facilities and Large Fleet Shops.



84275

Model 84275

Extra-heavy-duty dual reel sheave support base design and large hose capacity make this 1/2" (inlet/outlet) reel the ideal high-pressure reel for grease, petroleum oils, air and water.



84432

Model 84672

Extra-heavy-duty high flow design makes this 3/4" inlet/outlet reel the perfect medium-pressure reel for petroleum oils, used fluid evacuation, air and water service.

Model 84673

Extra-heavy-duty dual reel sheave support base, high flow design and large hose capacity make this 3/4" inlet/outlet reel the ideal medium-pressure reel for petroleum oils, used fluid evacuation, air and water service.

Model 84432

Dual reel sheave support base design and high-flow swivel make this 1" inlet/outlet reel the ideal low-pressure/volume reel. This reel is suitable for gasoline, diesel fuel, fuel oil, air and water. Not suitable for ceiling or wall mounted applications.



84672

High-Flow Reel Specifications

Model	Designation	SAE	HOSE CAPACITY		Inlet/Outlet NPT(f)	Working Pressure psi	Sheave Width	INSTALLATION	
			Type	Length				Width	Depth
84275	Extra-heavy-duty large capacity	100R1	78	75'	1/2"	5000	10"	13 1/8"	12 3/4"
		100R2	75/76A/76B	75'					
		100R3	73	75"					
84672	Extra-heavy-duty high flow	100R1	3/4"ID x 1 1/4"OD	30'	3/4"	2000	5 1/2"	9 15/16"	12 3/4"
		100R3	73	50'					
		100R6	74	50"					
84673	Large capacity	100R1	3/4"ID x 1 1/4"OD	75'	3/4"	2000	10"	14 1/2"	12 3/4"
		100R1	78	75'					
84432	Heavy-duty volume	100R3	1"OD low pressure	50'	1"	300	8"	15 3/4"	24 1/4"
89010	Super-duty high flow	100R3	1 1/4"ID x 1 3/4"OD low pressure	50'	1 1/4"	500		22 1/8"	26 1/4"

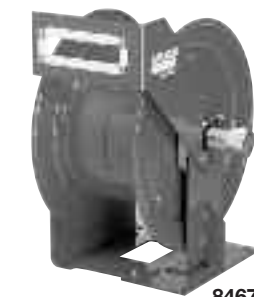

84673



84432



The Dual Arm Heavy-Duty Series was designed for the most rigorous and demanding environments. The Dual Arm and Base provide extra support for heavy and frequent use in vehicle maintenance garages, on lube trucks for both on- and off-road applications and in industrial settings.

Features and Benefits

- Hose guide is supported by two arms to absorb the forces subjected with frequent hose pull-out and retraction.
- Double base support to withstand the extra vibrations in rigorous environments
- Bare reel rated for high, medium and low pressures
- Dual needle bearings provide consistent and smooth hose pull-out and retraction
- Quick-disconnects on delivery and connection hose for simple installation
- Powder painted for long life and scratch resistance
- Reel assemblies available in hose lengths up to 60' and are factory pressure tested to insure quality leak-free installations
- Backed by a five-year limited warranty—see your Lincoln representative for details

Specifications

Model	Description	Hose	Application	Working Pressure	Sheave Width	Inlet/Outlet
83206	Bare Reel	N/A	High, Medium and Low	8000 psi* (544 bar)	5 1/2"	1/2" NPT(f)
83201	3/8" x 60' LP	RMA Class A	Low	250 psi (17 bar)		
83202	1/2" x 50' MP	73 / 100R3	Medium	1500 psi (102 bar)		
83203	3/8" x 50' HP	76B / 100R2	High	4000 psi (272 bar)		

* Operating at maximum working pressure should not exceed the pressure rating of the installed hose. Contact your Lincoln representative for additional reel assembly models.

Maximum Hose Capacities	Maximum Length
1/4" ID Air/water hose (RMA Class A or SAE 100R6)	60'
1/4" ID Grease hose (SAE 100R2)	
3/8" ID Air/water hose (RMA Class A or SAE 100R6)	
3/8" ID Grease hose (SAE 100R2)	
1/2" ID Air/water hose (RMA Class A or SAE 100R6)	
1/2" ID Oil hose (SAE 100R3)	
1/2" ID Grease hose (SAE 100R2)	
5/8" ID Oil hose (SAE 100R1)	

60' hose should be used on installations with a ceiling of 20' and higher allowing for a 10' to 12' hose hang down.

Air Reel – Value Series



Lincoln's Value Series air hose reels are constructed of durable, heavy-gauge steel and heavy-duty rubber air hoses. The slotted mounting base allows for easy attachment to ceilings, walls and work benches. Features include five-position adjustable outlet roller arm, spring-powered automatic recoil, angled hose guide for smooth, parallel hose pull-out and retraction and an eight-position ratchet gearing that locks the reel at the desired hose length. Designed for light to medium in-shop applications. Not recommended for outdoor, lube truck or other heavy-duty usage.

Model 83753

3/8" x 50' assembled air hose reel includes bare hose reel, 50' delivery hose and ball stop.

Model 83754

1/2" x 50' assembled air hose reel includes bare hose reel, 50' delivery hose and ball stop.

Specifications

Model	Assembly Description	Inlet/Outlet Connection	Maximum Pressure	Maximum Air Flow
83753	50' of 3/8" air hose	1/4" NPT	300 psi	25 cfm
83754	50' of 1/2" air hose	1/2" NPT	300 psi	35 cfm

Replacement Hose

Model	Assembly Description	Inlet/Outlet Connection	Maximum Pressure	Maximum Air Flow
275173	50' of 1/2" air hose	1/2" NPT	300 psi	35 cfm
275172	50' of 3/8" air hose	1/4" NPT	300 psi	25 cfm

Ball Stops

Lincoln Ball Stops are used to cushion and stop hose retraction.



85515

Model	Description	Hose Type	Hose OD
85515	Adjustable	72	5/8"
85516	Adjustable	72A & 74	11/16" – 23/32"
85517	Adjustable	73, 74, 76A & 76B	27/32" – 31/32"
84347	Adjustable	78	11/32"
84122	Adjustable	NA	13/4" – 17/8"
84257	Adjustable	NA	11/2" – 15/8"

Lubrication Tools and Equipment

Hose/Hose Adapters for Reels



Lincoln high-, medium- & low-pressure hoses—every size for every application

High-Pressure Hose—Grease

Model	Size	Hose Type/SAE	Inches		Thread	Max Pressure psi (bar)
			ID	OD		
75024	2'	75/100R2A	1/4	11/16	1/2"-27(f)	5000(340)
75060	5'	75/100R2A	1/4	11/16	1/2"-27(f)	5000(340)
75084	7'	75/100R2A	1/4	11/16	1/2"-27(f)	5000(340)
75120	10'	75/100R2A	1/4	11/16	1/2"-27(f)	5000(340)
75168	14'	75/100R2A	1/4	11/16	1/2"-27(f)	5000(340)
75240	20'	75/100R2A	1/4	11/16	1/2"-27(f)	5000(340)
75360	30'	75/100R2A	1/4	11/16	1/2"-27(f)	5000(340)
75480	40'	75/100R2A	1/4	11/16	1/2"-27(f)	5000(340)
75600	50'	75/100R2A	1/4	11/16	1/2"-27(f)	5000(340)
76024B	2'	76B/100R2	3/8	27/32	1/2"NPT(f)	4000(272)
76120B	10'	76B/100R2	3/8	27/32	1/2"NPT(f)	4000(272)
76360B	30'	76B/100R2	3/8	27/32	1/2"NPT(f)	4000(272)
76600B	50'	76B/100R2	3/8	27/32	1/2"NPT(f)	4000(272)
76900B	75'	76B/100R2	3/8	27/32	1/2"NPT(f)	4000(272)
76024A	2'	76B/100R2	1/2	27/32	1/2"NPT(f)	4000(272)
76600A	50'	76B/100R2	1/2	27/32	1/2"NPT(f)	4000(272)

Medium-Pressure Hose—Oil, Gear Lube & Antifreeze

73024	2'	73/100R3	1/2	13/16	1/2"NPT(m)	1500(102)
73036	3'	73/100R3	1/2	13/16	1/2"NPT(m)	1500(102)
73060	5'	73/100R3	1/2	13/16	1/2"NPT(m)	1500(102)
73120	10'	73/100R3	1/2	13/16	1/2"NPT(m)	1500(102)
73240	20'	73/100R3	1/2	13/16	1/2"NPT(m)	1500(102)
73360	30'	73/100R3	1/2	13/16	1/2"NPT(m)	1500(102)
73480	40'	73/100R3	1/2	13/16	1/2"NPT(m)	1500(102)
73600	50'	73/100R3	1/2	13/16	1/2"NPT(m)	1500(102)
73900	75'	73/100R3	1/2	13/16	1/2"NPT(m)	1500(102)
1230120	10'	1230/100R2	3/4	1 1/4	3/4"NPT(m)	2250(153)

Low-Pressure Hose—Air & Water

72024	2'	72/100R6	1/4	5/8	1/4"NPT(m)	250(17.01)
72036	3'	72/100R6	1/4	5/8	1/4"NPT(m)	250(17.01)
72060	5'	72/100R6	1/4	5/8	1/4"NPT(m)	250(17.01)
72120	10'	72/100R6	1/4	5/8	1/4"NPT(m)	250(17.01)
72240	20'	72/100R6	1/4	5/8	1/4"NPT(m)	250(17.01)
72360	30'	72/100R6	1/4	5/8	1/4"NPT(m)	250(17.01)
72600	50'	72/100R6	1/4	5/8	1/4"NPT(m)	250(17.01)
72024A	2'	72A/100R6	3/8	23/32	3/8"NPT(m)	250(17.01)
72360A	30'	72A/100R6	3/8	23/32	3/8"NPT(m)	250(17.01)
72480A	40'	72A/100R6	3/8	23/32	3/8"NPT(m)	250(17.01)
72600A	50'	72A/100R6	3/8	23/32	3/8"NPT(m)	250(17.01)
74024	2'	74/100R6	1/2	27/32	1/2"NPT(m)	200(13.61)
74060	5'	74/100R6	1/2	27/32	1/2"NPT(m)	200(13.61)
74480	40'	74/100R6	1/2	27/32	1/2"NPT(m)	200(13.61)
74600	50'	74/100R6	1/2	27/32	1/2"NPT(m)	200(13.61)

Hose Accessories Nipples, Couplers & Bushings for Lincoln Grease Hose

Nipples

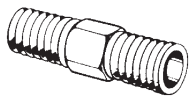

Model	Thread
10198	1/4" NPT(m) x 1/2"-27(m)
10199	1/8" NPT(m) x 1/2"-27(m)
10202	1/2"-27 NPT(m) x 1/2"-27(m)
12957	1/2" NPT(m) x 1/2"-27(m)

Bushings

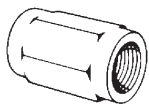

10200	1/8" NPT (f) x 1/2"-27(m)
10204	1/4" NPT(f) x 1/2"-27(m)
12287	1/2"-27(f) x 1/2" NPT(m)

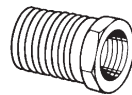

Reducing Couplings

11852	1/8" NPT(f) x 1/2"-27(f)
10522	1/4" NPT(f) x 1/2"-27(f)

Lincoln High-Pressure Replacement Hose Cross Reference

Model	Original Threads	Replacement
Alemite	1/2"-27(f) x 1/2"-27(f)	Any Type 75 Hose
Aro	1/8" NPT(m) x 1/8" NPT(f)	Any Type 75 Hose, 10199 Nipple, 10200 Bushing
Balcrank	1/2"-27(f) x 1/2"-27(f)	Any Type 75 Hose
Graco	1/4" NPT(m) x 1/4" NPT(m)	Any Type 75 Hose, Two (2) 10198 Bushing

Lincoln Control Valves, Meters and Accessories Provide the Durability and Precision You Need for Your Lubrication Systems.



740

Model 740 Heavy-Duty High-Pressure

- 7500 psi maximum operating pressure
- Precision-machined, all steel handle, body and guard bracket provides durability and longevity
- Unique, precision control inlet check valve provides ease of handle operation even with increase in pressure
- Knurled handle for positive grip
- Handy trigger guard prevents pinching
- Reversible inlet check seat and hydraulic jaws provide double life
- Balanced design reduces user fatigue
- Lubricant inlet 1/4" NPT(f); outlet 1/8" NPT(f)
- Easily repaired for extended life

Model 3050 Volume High-Pressure

Same as 740 except with 3/8" NPT(f) lubricant inlet for use with Lincoln volume high-pressure swivels and hose.

WARNING

Whip Hoses Models
3029, 3034, 5812,
5818, 5861, 81725,
81726, 81795

Install as shown.

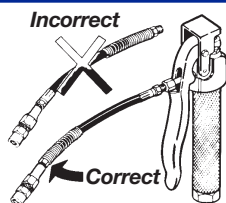

WARNING

For safe and proper use, always consult instructions accompanying product. See **Safety Warning Information** for appropriate warnings.

Model 82157 Repair Parts Kit

For control valves 740 and 3050.

High-Pressure Grease Control Valve

Model	Description	Thread Size	Extension	Coupler	Valve
740	Heavy-Duty	1/4" NPT(f)	Rigid Tube	5845	82393
3050	Volume	3/8" NPT(f)	Rigid Tube	5845	81495

Model 85021 Kit

Consists of 740 control valve and 81387 universal "z" swivel.

Swivels

Volume High-Pressure Swivels

Model	Description	Thread Size
81728	Straight	1/2" NPT(m) x 3/8" NPT(m)
82072	Straight	1/2" NPT(m) x 1/2" NPT(m)
82087	90° Angle	1/2" NPT(m) x 1/2" NPT(m)
81729	Universal	1/2" NPT(m) x 3/8" NPT(m)
82073	Universal	1/2" NPT(m) x 1/2" NPT(m)

Model 82158 Repair Kit

Repair Parts Kit for 81387 standard universal swivel.

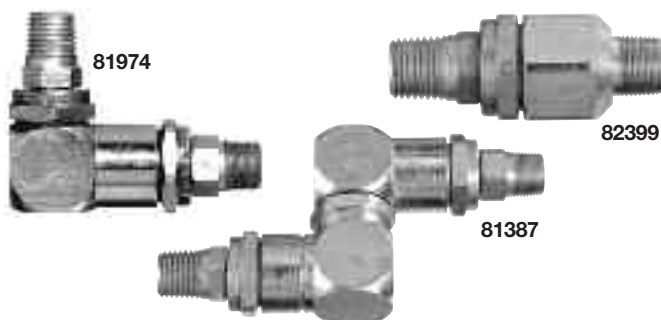

High-Pressure Swivels

Model	Description	Thread Size
*81606	Straight	1/8" NPT(f) x 1/8" NPT(m)
*81703	Straight	1/8" NPT(m) x 1/8" NPT(m)
82080	Straight	1/2"-27 (m) x 1/2"-27 (m)
82399	Straight	1/2"-27 (m) x 1/4" NPT(m)
81386	90° Angle	1/2"-27 (m) x 1/8" NPT(m)
81723	90° Angle	1/8" NPT(m) x 1/8" NPT(f)
81974	90° Angle	1/2"-27 (m) x 1/4" NPT(m)
82251	90° Angle	1/8" NPT(m) x 1/8" NPT(m)
81387	Universal	1/2"-27 (m) x 1/4" NPT(m)
82252	Universal	1/8" NPT(m) x 1/8" NPT(m)
83594	Universal	1/4" NPT(m) x 1/4" NPT(m)
83938	Straight	1/4" NPT(m) x 1/4" NPT(m)

*Whip Hose only; max. pressure 4500psi

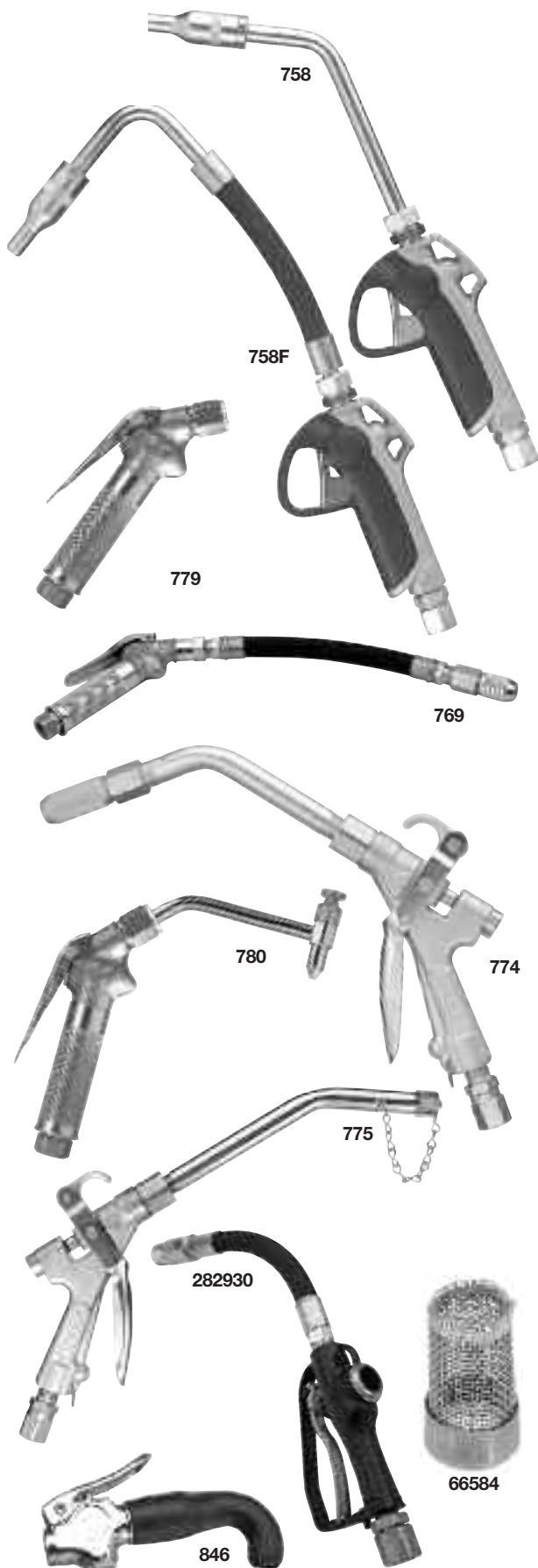

Heavy-Duty Fluid Control Valves

These new fluid control valves provide all the benefits of the latest design technology and offer all the features and components for a low-cost solution for your fluid dispensing needs.

- Rugged aluminum construction
- Dispenses all automotive fluids: motor oils, gear oils, transmission fluid and antifreeze
- All indoor and outdoor applications

Model 780

Gear oil shut-off valve for use with fluid lubricant pumps. Includes shut-off valve with built-in swivel and 82070 non-drip nozzle extension. Inlet 1/2" NPT(f).

Model 769

Includes 780 valve with built-in swivel, flexible extension and 91392 nozzle.

Model 758

Includes 260381 rigid extension. Inlet/outlet 1/2" NPT(f). Can be locked in open position for continuous dispensing. Trigger guard prevents accidental dispensing. 1015 psi (70 bar) maximum operating pressure. 5 GPM flow.

Model 758F

Same as 758 except with flexible extension.

Heavy-Duty Volume

Model 774

Includes 82906 shut-off valve and 242503 pipe extension and 91392 automatic nozzle.

Model 775

Includes 82906 shut-off valve and 82932 rigid extension nozzle.

Model 776

Includes 82906 shut-off valve and 12" flexible hose and 91392 non-drip nozzle with manual shut-off.

Model 779

Gear oil shut-off valve for use with fluid lubricant pumps.

Model 282930

High-flow valve rated up to 15 gpm and 1500 psi. Includes flexible extension and manual nozzle.

Oil Control Valves

Model	Description	Inlet Thread Size	Extension	Nozzle
780	Gear Oil	1/2 NPT(f)	Rigid Pipe	82070
758	STD Volume	1/2 NPT(f)	Rigid Assembly	260381
758F	STD Volume	1/2 NPT(f)	Flex Assembly	260380
774	HD Volume	1/2 NPT(f)	Rigid Pipe	91392
775	HD Volume	1/2 NPT(f)	Rigid Pipe	82932
776	HD Volume	1/2 NPT(f)	Flex Hose	91392
282930	High Flow	3/4 NPT(f)	Flex Hose	282941 Kit

Model 66584 Strainer

For use with 775, 776, 82906. #30 mesh, 9/16" OD.

Air & Water Accessories

Model 846 Water Bibb Cock

For attaching to water service hose.

- 1/4" NPT(f) inlet.
- Thumb-action trigger. Built-in strainer filters out contaminants.



Electronic Lube Meters Features

- Dispense motor oil, ATF and gear lube
- One model can dispense pints, quarts, liters or gallons
- Automatic non-drip nozzle
- Narrow nozzle fits into small I.D. ATF fill tubes
- Easy-to-read digital display for accurate bulk dispensing
- .01 increment readout for precise measurement
- Includes inline swivel, rigid extension, automatic non-drip nozzle and inline containment filter

Electronic Lube Meters

Totalizing liters or gallons. 1/2" NPT(f).

Model	Lock-On/Lock-Open	Extension	psi	gpm
905*	Rigid/ 70°/Auto nozzle	Yes	1000	5.0*
905SF**	For water-based solutions	Yes	1000	5.0
954	Flexible with auto nozzle	Yes	1500	6.0
953	Rigid/30°/Auto tip	Yes	1500	6.0
967	Flexible w/ 84799 nozzle	Yes	1500	4.0

8.0 gpm without nondrip nozzle. ** Models 905 and 905SF offers preset mode

Value-Priced Electronic Lube Meter

New value-priced control valve includes large digital display, shroud protector and trigger guard. 1/2" NPT(f) inlet swivel. Flexible manual nozzle.

Model	Measure	Extension	psi	gpm
952	quarts	Flexible/90° manual tip	1500	6.0

Mechanical Lube Meters

Totalizing meters. 3 1/2" diameter, inlet/outlet 1/2" NPT(f).

Model	Dial Totals	Graduation	Extension	psi	gpm
Oils, ATF and Antifreeze					
867*	16 gallons	1/16 gallon	10" flex w/ 84799	1000	4.0
876*	16 quarts	1/4 quart	4" rigid w/ 93548	1000	4.0
877*	16 quarts	1/4 quart	10" flex w/ 84799	1000	4.0
883*	16 quarts	1/4 quart	20" flex w/ 84799	1000	4.0
68410	16 quarts	1/4 quart	None	1000	4.0
899*	10 liters	1/10 liter	10" flex w/ 84799	1000	4.0
Gear Lube					
878	8 pints	1/16 gallon	7" rigid w/ nozzle	1000	4.0
881	10 liters	1/10 liter	7" rigid w/ nozzle	1000	4.0
Pre-set Countdown for Oils, ATF and Antifreeze					
3866*	16 quarts/10 liters	1/16 gallon	Rigid w/ 93548	1000	4.0
3867*	60 quarts	1/4 quart	Rigid w/ 93548	1000	4.0
3868*	60 gallons	1/4 quart	Rigid w/ 93548	1000	4.0
3942*	60 liters	1/10 liter	Rigid w/ 93548	1000	4.0

* 1/2" NPT(f) straight swivel (90464).

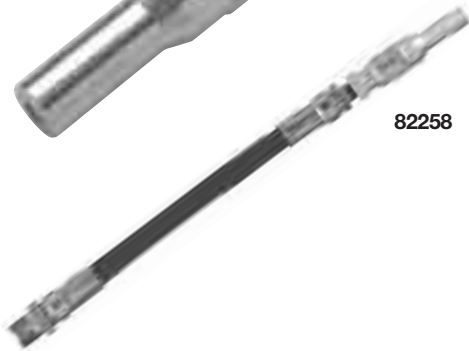
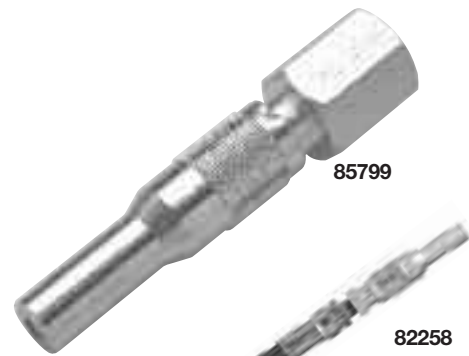

Non-Drip Nozzles & Assemblies

Model 93547 Nozzle

1/4" NPT(f) inlet automatic non-drip nozzle **with manual closure feature.** For packaged version, please use model 84799.

Model 93548 Nozzle

Same as 93547 with 1/2" NPT(m) inlet.

Model 85799 Nozzle

Same as 84799 with 1/2" NPT (f) inlet.

Model 91392 Nozzle

1/2" NPT(f), features manual shut-off.

Model 82258 Assembly

1/2" x 1/4" NPT(m), 10" hose (91241) and 1/4" NPT(f) automatic non-drip nozzle (93547).

Electronic Meter Accessories

Model 260379

Rigid extension outlet with patented 45° swivel for versatile fluid dispensing.

Model 260380

Flexible extension with non-drip valve for fluid dispensing in hard-to-reach areas.

Model 260381

Rigid extension with non-drip valve.

Colored Swivel Guards

Attach these flexible swivel guards to separate meters to differentiate between fluids. Available in red, black, blue, yellow and green.

Meter Accessories

Model 242911 Shroud Protector

Universal shock protector for all 3 1/2" diameter Lincoln electronic lube meters. Heavy-duty rubber cover fits easily over meter face. Order as separate accessory.

Model 90464 Swivel

Straight oil meter swivel, 1/2"NPT(m) x 1/2"NPT(f). 1000 psi (68 bar) maximum working pressure.





840

Blow Guns

Model 840

- Handy thumb-button design provides ease of operation
- Brass stem and synthetic packaging for service life
- Addition of air nipple permits quick connect or disconnect
- Inlet 1/4" NPT(f); outlet 7/64" diameter



960

Model 950

- Same as 840, except with air restricter
- Nozzle inlet pressure 30 psi maximum complies with Federal Safety Regulation 50-204.8 and OSHA 1910 242.B.



5980

Model 960

- Light-weight cast aluminum pistol grip
- Inlet 1/4" NPT(f); outlet 7/64" diameter; height 5 3/4"
- Nozzle inlet pressure 30 psi maximum complies with Federal Safety Regulation 50-204.8 and OSHA 1910 242.B.

Model 940

- Same as 960 less air restricter
- When used for large cleaning requirement or chip cleaning, regulated air pressure must not exceed Federal recommended maximum.



5990

Model 5980

- Thumb control provides comfort and ease of operation
- Inlet 1/4" NPT(f); outlet 1/8" NPT(f) outlet

Model 5990 Rubber Tip for Blow Guns

- Rubber tip will not scratch surfaces.
- Fits 840, 940 and 5980 blow guns, as well as many competitive models.
- 1/8" NPT(m) threads.

Air & Water Accessories

Model 846 Water Bibb Cock

For attaching to water service hose.

- 1/4" NPT(f) inlet.
- Thumb-action trigger. Built-in strainer filters out contaminants.



846

Model 845 Water Bibb Cock

Same as 846 except inlet 3/4"-1 1/2" AN connects to standard lawn hose.

Air/Water Accessories

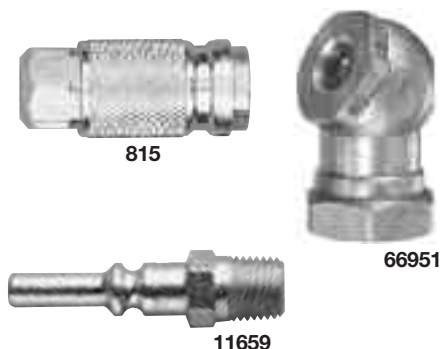

815

66951

11659

Model	Description	Style
845	Inlet 3/4" -1 1/2" AN	Connects to standard lawn hose
846	1/4"(f) Water Bibb Cock	Low-pressure water
815	1/4"(f) Air Coupler	Lincoln "Long Stem"
11659	1/4"(m) Air Nipple	Lincoln "Long Stem"
66951	1/4"(f) Tire Chuck	Standard tire chuck



815 1/4" (f)



815 Cut-away



11659 1/4" (m) 11660 1/8" (m)



11661 1/4" (f)



13329 1/4" (m)



13331 1/4" (f)

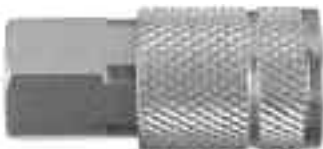

5874 3/8" (f)



5875 3/8" (m)

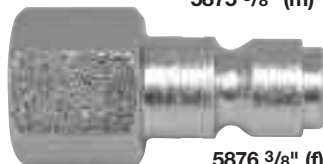

5876 3/8" (f)

Coupler and nipple can be joined without user pulling back on sleeve.
A true quick-connect design!

Lincoln-Style Couplers for 1/4" ID Model 815

250 psi maximum operating pressure. 1/4" NPT(f) inlet. Extra-long stem of nipple and coupler body assures long service life, easy connections under severe operating conditions. Maximum air flow 52 scfm at 100 psi. Length 2 1/2" (65mm); diameter 1 1/16" (37mm); weight 4 1/2" ounces (126g).

- Positive action locking mechanism so coupler cannot be detached accidentally.
- Extra-large air passage insures greater air flow.
- Automatic air check valve shuts off air instantly when uncoupled, providing leak-proof seal.
- Corrosion-resistant steel plug and stainless steel check and check spring for long service life.
- Free swiveling action prevents curling or kinking of air hose.

Lincoln-Style Nipples for 1/4" ID Model 11659, 11660, 11661

For use with model 815 coupler

Universal Coupler Model 5862

Fits all Automotive/Tru-Flate, ARO, and Industrial-/Milton-style nipples for 1/4" ID hose 300 psi maximum operating pressure. 1/4" (f) NPT inlet. Maximum airflow 38 scfm at 100 psi. Length 2"; diameter 1 1/8"; weight 4 ounces.

Coupler and nipple can be joined without user pulling back on sleeve.
A true quick-connect design!



5862

ARO-Style Couplers & Nipples for 1/4" ID Models 5862, 13329, 13331

Fits ARO style nipples for 1/4" ID hose. 300 psi maximum operating pressure. 1/4" (f) NPT inlet. Maximum airflow 38 scfm at 100 psi. Length 2"; diameter 1 1/8"; weight 4 ounces.

Automotive-/Tru-Flate-Style Couplers & Nipples for 3/8" ID Models 5874, 5875, 5876

300 psi maximum operating pressure. Maximum air flow 100 scfm at 100 psi. Length 2 3/8"; diameter 1"; weight 4.8 ounces.

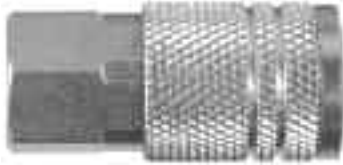

632004 1/4" (f)



630104 1/4" (m)



630204 1/4" (f)

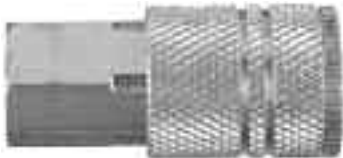

642006 3/8" (f)



640104 1/4" (m)



640204 1/4" (f)



652008 1/2" (f)



650108 1/2" (m)



650208 1/2" (f)

KEY—How to Identify Model Desired

xx	x	x	xx
Series	0 = nipple 2 = coupler	1 = male 2 = Female	thread size IN 1/16"

Industrial-/Milton-Style Couplers & Nipples for 1/4" ID (63 Series)

Models 632004, 630104, 630204

Maximum operating pressure 250 psi (17 bar). Maximum air flow 45 scfm at 100 psi. Length 1 3/4" (44mm); diameter 1 1/8" (29mm); weight 3 ounces (84g).

Industrial-Style Couplers & Nipples for 3/8" ID (64 Series)

Models 642006, 640104, 640204, 640106, 640206

Maximum operating pressure 250 psi. Maximum air flow 108 scfm at 100 psi. Length 2 1/16" (52mm); diameter 1 5/16" (49mm); weight 6 ounces (168g).

Industrial-Style Couplers & Nipples for 1/2" ID (65 Series)

Models 652008, 650108, 650208

Maximum operating pressure 200 psi (14 bar). Maximum air flow 176 scfm at 100 psi. Length 2 3/4" (70mm); diameter 1 1/2" (38mm); weight 9 ounces (252g).



939



5983

Air-Operated Sprayers

Model 939

- Adjustable suction control varies fluid volume as needed.
- Strainer assembly in suction hose keeps out contaminants while assuring uninterrupted flow of fluid.
- 6' vinyl suction hose permits use with most any container from gallon jug to 400 lb. drum.
- Convenient addition of air coupler nipple permits quick coupling to any air hose.
- Rust and corrosion resistant—pistol grip handle includes brass stem and synthetic packing.
- Use with solvents or detergent solutions. Compatible with vinyl, aluminum and carbon steel.
- Standard air inlet 1/4" NPT(f).
- Powerful spray. Maximum operating pressure 200 psi.

Model 5983

- Use with solvents or detergent solutions.
- 1/4" NPT(f) inlet.
- Maximum operating pressure 150 psi.

Tire Accessories

Model 80423 Tire Inflator

- 12" hose extension provides extra-reach capacity.
- Tapered chuck nut allows inflator to fit wheel covers on cars and light trucks.
- Dual chuck permits use of gauge on trucks with dual tires.
- Includes 11659 nipple for use with 815 coupler. 200 psi maximum inlet pressure. 0-120 psi scale in 2 psi graduations.

80423



Model 66951 Air Chuck

For inflating tire. 1/4" NPT(f) inlet.

Self-Coiling Air Hose

Model 84606

- Tough abrasive resistant material provides long service life.
- Coiled spring guards prevent kinking.
- 1/4" I.D. x 25' long—extra length for those hard-to-reach places.
- Working pressures up to 200 psi.
1/4" NPT(m) fittings each end.

Note: Blow guns on page 54.



66951



84606

Lincoln Regulators, Filters & Lubricators

A well-planned compressed air system ensures minimum pressure loss in the system and the removal of contaminants: water, compressor oil, etc. An inefficient system results in higher costs per unit of compressed air, improper or erratic tool operation, shortened component life and reduced capacity. Lincoln provides individual components and combined component systems to give you the highest quality for your compressed air tool operations.

Changes in air pressure can affect the performance of air-powered equipment. Most equipment will operate beyond recommended pressure, but this causes excess torque, force and wear and wastes compressed air. Lincoln air regulators eliminate this problem by providing the consistent pressure required for each tool, ensuring maximum life and working efficiency for your pneumatic equipment.

Air filters are essential for proper performance of air powered tools, equipment and machinery. Lincoln filters are designed to minimize water vapor and contaminants in the air supply. Install a large filter in the main distribution line immediately after the compression accumulator tank. Another smaller filter should be placed inline within 20 feet of the equipment it will protect. This ensures the removal of solid particles at point of use and most condensed moisture.

Most air-operated tools, equipment and components of air systems require oil lubrication for proper function and to ensure long service life. Lincoln air line lubricators are designed to meter precise amounts of lubricant into the air supply, improving the efficiency of cylinders, valves and air motors. Lubrication is automatically provided in a nearly constant oil-to-air ratio over a wide range of air flows. Air passing through the operated device is a very fine mist that can be carried over a long distance, serving more than one tool at a time.

Miniature Units

Model 600003 Miniature Regulator

All brass construction with Buna N diaphragm. For 1/4" pipe size. Maximum supply pressure 300 psig. Reduced pressure range: 0-125 psig. Operating temperature range: -40° to 180°F. Diameter 1 3/8", height 2 3/4", weight 1/2 lb.

Model 600103 Miniature Filter

All brass construction with porous bronze filter (20 micron) element and shatter proof polycarbonate bowl. For 1/4" pipe size. Maximum supply pressure 200 psi. Maximum operating temperature 120°F. Diameter 1 9/16", height 4", weight 3/8 lb.

Model 600203 Miniature Lubricator

All brass construction with shatterproof polycarbonate bowl. For 1/4" pipe size. Maximum supply pressure 200 psi. Maximum operating temperature 120°F. Oil viscosity limitation not over 800 S.S.U. (SAE #30 not under 85°F). Diameter 1 9/16", height 4 3/8", weight 1/4 lb.



Gauges

Model 66100 Gauge

Registers pressures up to 200 psi. Dial diameter 2". 1/4" NPT(m) bottom connection. Calibrated both in psi and kg/cm2.

Model 66101 Gauge

Same as 66100 except 1/8" NPT(m) bottom connection.

Model 600401 Gauge

Same as 66100 except with 1/4" NPT center back connection.

Model 66111

Same as 66100 except registers to 5000 psi.



Air Line Equipment Accessories—Pressure Gauges

Available in 1/8" NPT and 1/4" NPT back connection.



Model No.	For Regulator Sizes	Gauge Dia.	Connection	Pressure Range
247843	1/4" and 3/8"	1 1/2"	1/8" NPT	0 to 160 / 0 to 11
247844	1/2", 3/4" and 1"	2"	1/4" NPT	0 to 300 / 0 to 20
247863				

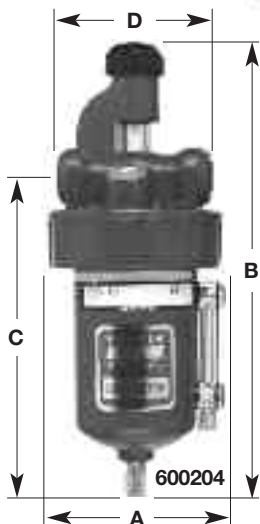
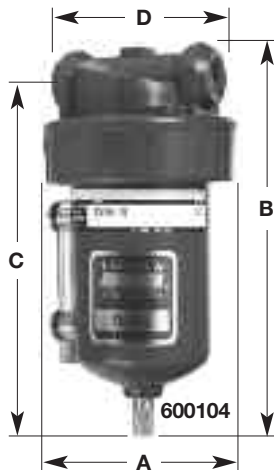
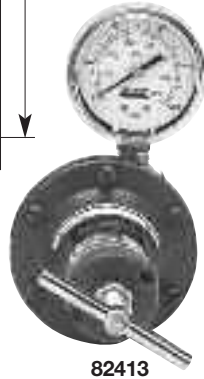
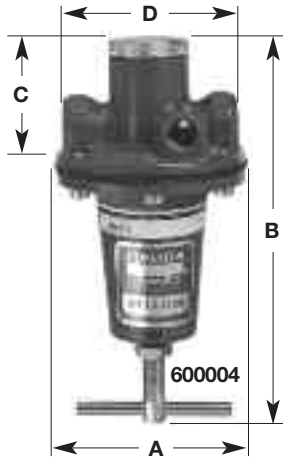

Regulators

Die-cast zinc construction with stainless steel strainer and renewable brass seat. Diaphragm and disc are oil-resistant Buna-N. Secondary pressure side gauge connections are 1/4" NPTF and are sealed with removable pipe plugs. Maximum supply pressure is 300 psi (20 bar) for all sizes listed. Operating range 0-250 psi (0-17 bar). Operating temperature range: 40°-120°F (4°-49°C).

Model	Pipe Size inches	A in (mm)	B in (mm)	C in (mm)	D in (mm)	Weight lbs (kg)
600004	1/4	3 (75)	6 (150)	1 3/8 (35)	2 3/8 (70)	1.8 (0.8)
600006	3/8	3 (75)	6 (150)	1 3/8 (35)	2 3/8 (70)	1.8 (0.8)
600008	1/2	3 9/16 (90)	7 (175)	1 1/2 (38)	3 1/4 (79)	2.8 (1.3)
600012	3/4	4 11/16 (119)	10 (254)	1 7/8 (48)	4 3/8 (111)	6.2 (2.8)
600016	1	4 11/16 (119)	10 (254)	1 7/8 (48)	4 3/8 (111)	6.2 (2.8)

82413 Control Assembly

Includes 66100 Gauge and 600004 Regulator. Inlet and outlet 1/4" NPTF.

Filters

Construction of die-cast zinc with 40 micron filter element of porous bronze. Metal bowl with sight glass. Maximum supply pressure 250 psi (17 bar). Maximum temperature 150°F (65°C).

Model	Pipe Size inches	Capacity oz (cc)	A in (mm)	B in (mm)	C in (mm)	D in (mm)	Weight lbs (kg)
600104	1/4	5 (148)	2 15/16 (75)	5 5/8 (143)	5 1/8 (130)	2 1/2 (64)	1.8 (0.8)
600106	3/8	5 (148)	2 15/16 (75)	5 5/8 (143)	5 1/8 (130)	2 1/2 (64)	1.8 (0.8)
600108	1/2	8 (237)	3 3/4 (95)	6 1/4 (159)	5 5/8 (143)	3 1/4 (83)	2.8 (1.3)
600112	3/4	16 (473)	4 7/8 (124)	8 3/4 (222)	7 3/4 (197)	4 9/16 (116)	6.3 (2.9)
600116	1	16 (473)	4 7/8 (124)	8 3/4 (222)	7 3/4 (197)	4 9/16 (116)	6.3 (2.9)

600301 Automatic Drain Conversion Kit

Converts manual drain filter to automatic drain. Increases filter efficiency and eliminates problem of manual draining.

Lubricators

Constructed of die-cast zinc. Metal bowl with sight glass. Maximum supply pressure 250 psi (17 bar). Maximum temperature 150°F (65°C). Oil viscosity maximum not over 800 S.S.U. (SAE 30, not under 85°F/29°C).

Note: Oil adjustment may be made tamper-proof by removing "Dial Set" knob on all models. All sizes may be filled while under pressure.

Model	Pipe Size inches	Capacity oz (cc)	A in (mm)	B in (mm)	C in (mm)	D in (mm)	Weight lbs (kg)
600204	1/4	5 (148)	2 15/16 (75)	7 5/8 (194)	5 5/8 (143)	2 1/2 (64)	2.2 (1)
600206	3/8	5 (148)	2 15/16 (75)	7 5/8 (194)	5 5/8 (143)	2 1/2 (64)	2.2 (1)
600208	1/2	8 (237)	3 3/4 (95)	8 1/8 (206)	5 3/4 (146)	3 1/4 (83)	3.3 (1.5)
600212	3/4	16 (473)	4 7/8 (124)	10 1/2 (267)	7 7/8 (200)	4 9/16 (116)	4.2 (1.9)
600216	1	16 (473)	4 7/8 (124)	10 1/2 (267)	7 7/8 (200)	4 9/16 (116)	4.2 (1.9)

Lincoln's MODULAR AirCare™ Regulators, Filters and Lubricators

- Modular components snap into place for quick assembly and service
- Wide selection of sizes, styles and capacities to meet specific application requirements

Modular Air Line Filters

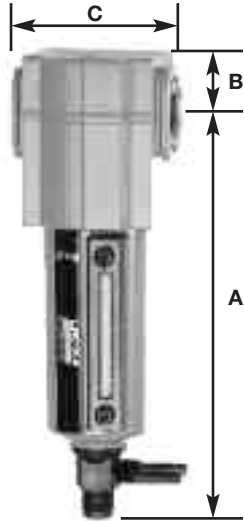

Model No.	Max. Air Supply psi / bar	Operating Temperature Range - F / C	Material of Construction		Element	
			Body	Bowl	Material	Particle Size
602104	250	0 to 150	Zinc	Zinc*	Sintered Polypropylene	40 μ
602106		-18 to 65				
602108		0 to 175	Aluminum	Aluminum*		
602109	-18 to 79					

* Transparent nylon liquid level indicator lens.

Model No.	Drain Type	Port Size PTF	Dimensions - in. / mm				Weight lbs. / kg
			A	B	C	Dia.	
602104	Manual	¼	5.27	0.75	1.98	1.91	1.1
602106		⅜	134	19	50	48	0.5
602108		½	6.95 / 177	1.00	3.15	2.89	1.8
602109	Automatic		6.35 / 161	25	80	74	0.8

Modular Air Line Regulators

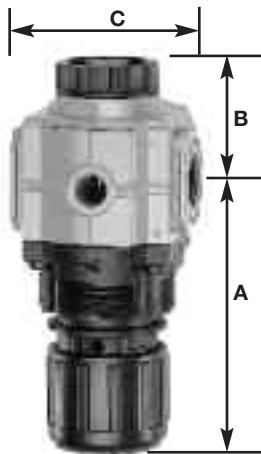

Model No.	Max. Air Supply psi / bar	Operating Temperature Range - F / C	Material of Construction				Secondary (Gauge) Connections (in.)
			Body	Bonnet	Valve Seals	Bottom Plug	
602004	300	0 to 150 -18 to 65	Zinc	Acetal	Brass Nitrile	Acetal	½ NPT (F)
602005							
602006							
602007	20	0 to 175 -18 to 79	Aluminum	Aluminum			
602008							
602009							

Model No.	Outlet Press. Adj. Range psi / bar	Connections NPT-Female (in.)	Dimensions - in. / mm				Adjuster	Weight lbs. / kg	
			A	B	C	D			
602004	5 to 150	¼	4.0 / 102	1.31	2.0	3.2	T-Handle	0.8	
602005			2.88 / 73				Knob		
602006	0.3 to 4	⅜	4.0 / 102	33	50	83	T-Handle		0.4
602007			2.88 / 73				Knob		
602008	10 to 250 0.7 to 16	½	5.95 151	1.69 43	3.15 80	5.1 130	T-Handle	1.77 0.80	
602009	5 to 150 0.3 to 4		5.0 127				Knob		

Modular Air Line Lubricators

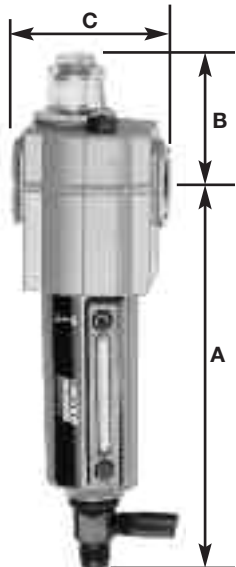

Model No.	Max. Air Supply psi / bar	Operating Temperature Range - F / C	Material of Construction			Recommended Lubricants
			Body	Bowl	Sight feed Dome	
602204	250	0 to 150	Zinc	Zinc*	Transp Nylon	Misting-type oil 50 to 200 SSU (ISO Grade 7 to 46) at 100°F (38°C)
602206		-18 to 65				
602208		0 to 175 -18 to 79	Aluminum	Aluminum*		

* Transparent nylon liquid level indicator lens.

Model No.	Connections NPT-Female	Bowl Capacity ozs. / ml	Dimensions - in. / mm				Weight lbs. / kg
			A	B	C	D	
602204	¼	2.0	5.27	1.63	1.98	1.91	1.1
602206		58	134	41	50	48	0.5
602208	½	7.0	6.95	2.12	3.15	2.89	1.6
		207	177	53	80	74	0.7

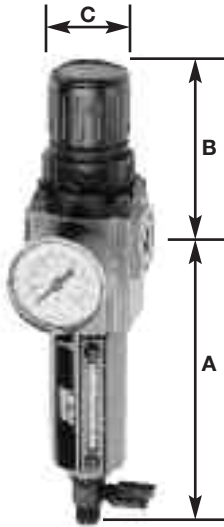

Integrated/Modular Filter/Regulator with Gauge

Can be used with other AirCare Modular Components.

Model No.	Max. Air Supply psi / bar	Operating Temperature Range - F / C	Element Particle Size	Outlet Pressure Adj. Range psi / bar			
602134	250	0 to 150	40 μ	5 to 150 0.3 to 10			
602136		-18 to 65					
602138		0.3 to 10 -18 to 79					
Model No.	Drain Type	Port Size PTF	Dimensions - in. / mm				Weight lbs. / kg
602134	Manual	¼	A	B	C	D	1.2
602136		¾	5.27	2.89	1.98	3.29	0.5
602138		½	6.95	4.98	3.15	5.10	2.6
			177	127	80	130	1.2

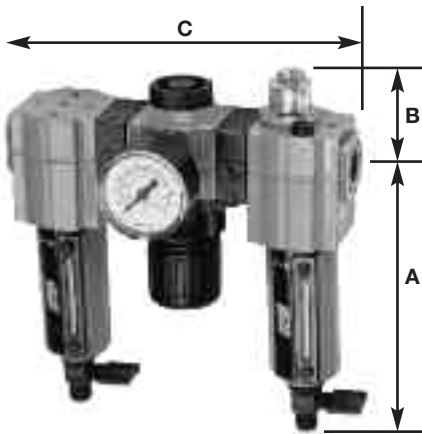

Modular Air Line Combination Units

Filter-Regulator with Gauge-Lubricator

Model No.	Max. Air Supply psi / bar	Operating Temperature Range - F / C	Element Particle Size	Outlet Pressure Adj. Range psi / bar	Lubricator Bowl Capacity ozs. / ml	
85387-4	250	0 to 150	40 μ	5 to 150 0.3 to 10	2.0	
85387-6		-18 to 65			58	
85387-8		0 to 175 / -18 to 79			7.0 / 207	
Model No.	Drain Type	Port Size PTF	Dimensions - in. / mm			Weight lbs. / kg
85387-4	Manual	¼	A	B	C	3.3
85387-6		¾	5.27	1.63	6.46	1.5
85387-8		½	6.95 / 177	2.12 / 53	10.52 / 267	6.2 / 2.8

* Transparent nylon liquid level indicator lens.



Modular Air Line Combination Units

Filter-Regulator with Gauge

Model No.	Max. Air Supply psi / bar	Operating Temperature Range - F / C	Element Particle Size	Outlet Pressure Adj. Range psi / bar		
85388-4	250	0 to 150 / -18 to 65	40 μ	5 to 150		
85388-8	17	0 to 175 / -18 to 79		0.3 to 10		
Model No.	Drain Type	Port Size PTF	Dimensions - in. / mm			Weight lbs. / kg
85388-4	Manual	¼	A	B	C	2.1 / 1.0
85388-8		½	5.27 / 134	1.31 / 33	4.22 / 108	4.2 / 2.0

* Transparent nylon liquid level indicator lens.

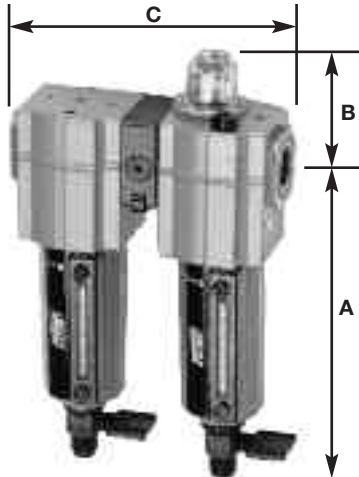

Modular Air Line Combination Units

Filter-Lubricator

Model No.	Max. Air Supply psi / bar	Operating Temperature Range - F / C	Element Particle Size	Lubricator Bowl Capacity ozs. / ml
85389-8	250 / 17	0 to 175 / -18 to 79	40µ	7.0 / 207

* Transparent nylon liquid level indicator lens.

Model No.	Drain Type	Port Size PTF	Dimensions - in. / mm			Weight lbs. / kg
			A	B	C	
85389-8	Manual	½	6.95 / 177	2.12 / 53	6.84 / 174	3.8 / 1.7



High-Capacity Air Line Filters

Model No.	Max. Air Supply psi / bar	Operating Temperature Range - F / C	Material of Construction		Element	
			Body	Bowl	Material	Particle Size
602112	250 17.2	0 to 175 -18 to 79	Aluminum	Aluminum* w/ Pyrex sight glass	Sintered bronze	50µ
602113						
602116						
602117						

* Pyrex liquid level indicator.

Model No.	Drain Type	Port Size PTF	Dimensions - in. / mm				Weight lbs. / kg
			A	B	C	Dia.	
602112	Manual	¾	10.44 / 265	1.25 32	4.75 121	5.52 140	4.1 1.9
602113	Automatic		10.06 / 256				
602116	Manual	10.44 / 265					
602117	Automatic	10.06 / 256					

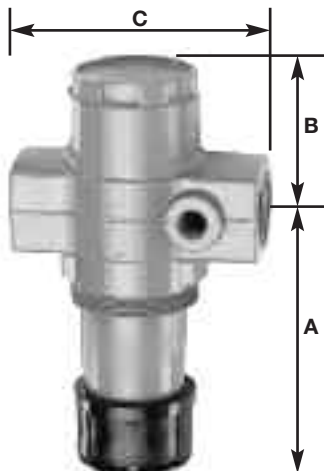

High-Capacity Air Line Regulators

Model No.	Max. Air Supply psi / bar	Operating Temperature Range - F / C	Material of Construction				Secondary (Gauge) Connections (in.)
			Body	Bonnet	Valve Seals	Bottom Plug	
602012	300 20	0 to 175 -18 to 79	Aluminum	Aluminum	Aluminum Nitrile	Aluminum	¼ NPT (F)
602013							
602016							

Model No.	Outlet Press. Adj. Range psi / bar	Connections NPT-Female in.	Dimensions - in. / mm				Adjuster	Weight lbs. / kg
			A	B	C	D		
602012	10 to 250 / 0.7 to 16	¾	5.69 / 145	2.38 60	4.25 108	2.38 60	T-Handle	2.5 1.1
602013	5 to 150 / 0.3 to 10		4.71 / 120				Knob	
602016	10 to 250 / 0.7 to 16	1	5.69 / 145				T-Handle	

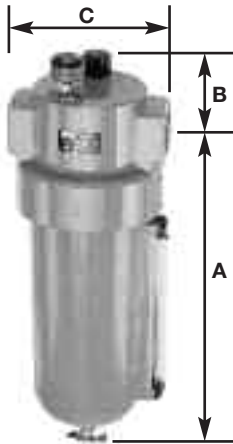

High-Capacity Air Line Lubricators

Model No.	Max. Air Supply psi / bar	Operating Temperature Range - F / C	Material of Construction			Recommended Lubricants
			Body	Bowl	Sight feed Dome	
602212	250	0 to 175	Aluminum	Aluminum*	Transp. Nylon	Misting-type oil 50 to 200 SSU (ISO Grade 7 to 46) at 100°F (38°C)
602216	17.2	-18 to 79				

* Pyrex liquid level indicator.

Model No.	Connections NPT-Female	Bowl Capacity ozs. / ml	Dimensions - in. / mm				Weight lbs. / kg
			A	B	C	Dia.	
602212	3/4	32	10.24	2.22	4.50	5.52	3.6
602216	1	946	260	56	114	140	1.6

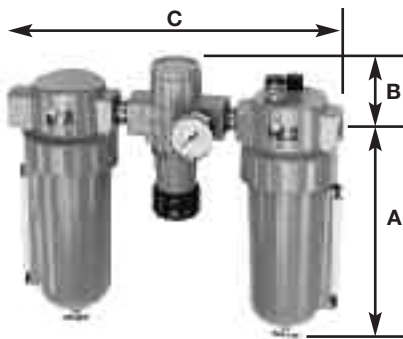

High-Capacity Air Line Combination Units

High Capacity Filter-Regulator with Gauge-Lubricator

Model No.	Max. Air Supply psi / bar	Operating Temperature Range - F / C	Element Particle Size	Outlet Pressure Adj. Range psi / bar	Lubricator Bowl Capacity ozs. / ml
85387-12	250	0 to 175	50μ	5 to 125	32
85387-16	17	-18 to 79		0.3 to 8.6	946

* Pyrex liquid level indicator.

Model No.	Drain Type	Port Size PTF	Dimensions - in. / mm			Weight lbs. / kg
			A	B	C	
85387-12	Manual	3/4	10.44	2.22	14.75	10.6
85387-16		1	265	56	375	4.8

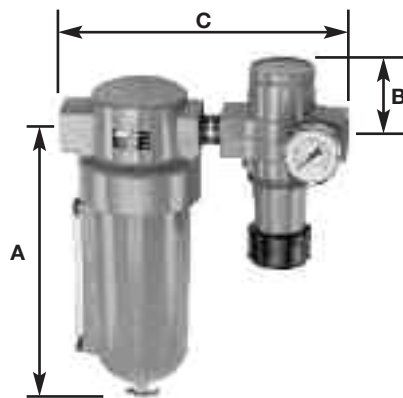

High-Capacity Air Line Combination Units

Filter-Regulator with Gauge

Model No.	Max. Air Supply psi / bar	Operating Temperature Range - F / C	Element Particle Size	Outlet Pressure Adj. Range psi / bar
85388-12	250	0 to 175	50μ	5 to 125
	17	-18 to 79		0.3 to 8.6

* Pyrex liquid level indicator.

Model No.	Drain Type	Port Size PTF	Dimensions - in. / mm				Weight lbs. / kg
			A	B	C	Dia.	
85388-12	Manual	3/4	10.44	2.38	10	5.52	6.9
		265	60	254	140	3.1	

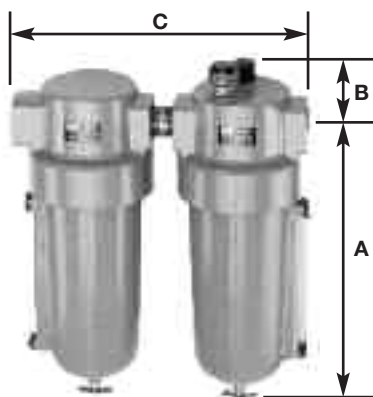

High-Capacity Air Line Combination Units

Filter-Lubricator

Model No.	Max. Air Supply psi / bar	Operating Temperature Range - F / C	Element Particle Size	Lubricator Bowl Capacity ozs. / ml
85389-12	250	0 to 175	50μ	32
85389-16	17	-18 to 79		946

* Pyrex liquid level indicator.

Model No.	Drain Type	Port Size PTF	Dimensions - in. / mm				Weight lbs. / kg
			A	B	C	Dia.	
85389-12	Manual	3/4	10.44	2.22	10.25	5.52	7.8
85389-16		1	265	56	260	140	3.5



Miniature Air Line Components—Air Line Filter

Model No.	Max. Air Supply psi / bar	Operating Temperature Range - F / C	Material of Construction		Element		
			Body	Bowl	Material	Particle Size	
602103	150 10.3	0 to 125 -18 to 52	Zinc	Polycarbonate	Porous Polypropylene	50μ	
Model No.	Drain Type	Port Size PTF	Dimensions - in. / mm				Weight lbs. / kg
			A	B	C	Dia.	
602103	Manual	¼	3.25 / 83	0.38 / 10	1.63 / 42	1.45 / 37	0.3 / 0.12



Miniature Air Line Components—Air Line Regulator

Model No.	Max. Air Supply psi / bar	Operating Temperature Range - F / C	Material of Construction				Secondary (Gauge) Connections-in.	
			Body	Bonnet	Valve Seals	Bottom Plug		
602003	300 / 20	0 to 150 -18 to 65	Zinc	Acetal	Brass/ Nitrile	Acetal	½ NPT (F)	
Model No.	Outlet Press. Adj. Range psi / bar	Connections NPT-Female in.	Dimensions - in. / mm				Adjuster	Weight lbs. / kg
			A	B	C	D		
602003	5 to 100 0.3 to 6.9	¼	2.52 64	0.39 10	1.63 41	1.45 37	Knob	0.3 0.13

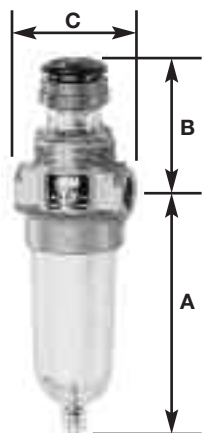

Miniature Air Line Components—Air Line Lubricator

Model No.	Max. Air Supply psi / bar	Operating Temperature Range - F / C	Material of Construction			Recommended Lubricants	
			Body	Bowl	Sight feed Dome		
602203	150 10.3	0 to 125 -18 to 52	Aluminum	Poly- carbonate	Transp. Nylon	Misting-type oil 50 to 200 SSU (ISO Grade 7 to 46) at 100°F / 38°C	
Model No.	Connections NPT-Female in.	Bowl Capacity ozs. / ml	Dimensions - in. / mm				Weight lbs. / kg
			A	B	C	Dia.	
602203	¼	1.0 / 30	3.25 / 83	1.98 / 50	1.63 / 41	1.45 / 37	0.3 / 0.13

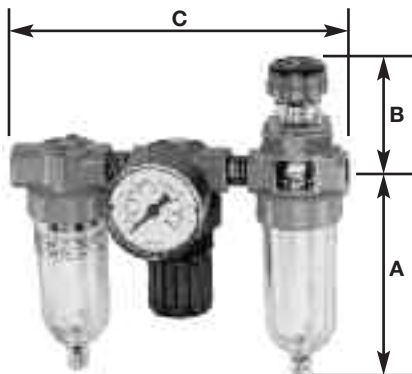

Miniature Air Line Combination Units

Filter-Regulator with Gauge-Lubricator

Model No.	Max. Air Supply psi / bar	Operating Temperature Range - F / C	Element Particle Size	Outlet Pressure Adj. Range psi / bar	Lubricator Bowl Capacity ozs. / ml		
85672	150 / 10.3	0 to 150 / -18 to 65	50μ	5 to 100 / 0.3 to 6.9	1.0 / 30		
Model No.	Drain Type	Port Size PTF	Dimensions - in. / mm				Weight lbs. / kg
			A	B	C	Dia.	
85672	Manual	¼	3.25 / 83	1.98 / 50	5.61 / 143	1.45 / 37	1.3 / 0.6



Miniature Air Line Combination Units

Filter-Lubricator

Model No.	Max. Air Supply psi / bar	Operating Temperature Range - F / C	Element Particle Size	Lubricator Bowl Capacity ozs. / ml			
85674	150 / 10.3	0 to 125 / -18 to 52	5 μ	1.0 / 30			
Model No.	Drain Type	Port Size PTF	Dimensions - in. / mm				Weight lbs. / kg
			A	B	C	Dia.	
85674	Manual	1/4	3.25 / 83	1.98 / 50	3.66 / 93	1.45 / 37	0.9 / 0.4

Modular Air Line Equipment Accessories— Lockout Valve

Install in-line or modular with other AirCare products to help conform to OSHA Lockout Regulations. In the closed position, valves block inlet air flow and exhaust downstream air.



Model No.	For Modular use with	For In-Line use with	Max. Air Supply psi / bar	Operating Temperature Range-F / C
247770	1/4" Modular	1/4"	250 17	0 to 150 -20 to 65
247771	3/8" Modular	3/8"		
247772	1/2" Modular	1/2"		

Modular Air Line Equipment Accessories— Quick Clamp

Use with Modular Air Line Components to provide modular installation capability. Flanges on the products slide into "V" grooves in the quick clamp. Two face-sealing o-rings in the quick clamp provide an air tight connection when the clamp is closed.



Model No.	For Modular Sizes	Dimensions in. / mm
247782	1/4" and 3/8"	1.50 / 38
247783	1/2" and 3/4"	2.00 / 51

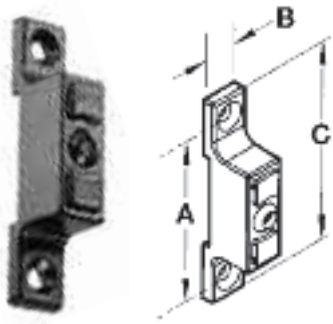

**Modular Air Line Equipment Accessories—
 Quick Clamp Wall Mounting Bracket**

Use with quick clamp to provide secure mounting to a wall, machine panel or other flat surface.

Model No.	For Modular Sizes	Dimensions in. / mm		
		A	B	C
247792	¼" and ⅜"	2.32 / 59	0.55 / 14	2.91 / 74
247793	½" and ¾"	3.25 / 83	0.95 / 24	4.0 / 102



**Modular Air Line Equipment Accessories—
 Quick Mount Pipe Adaptors**

Use with quick clamp to provide threaded connections to the system piping.

Model No.	For Modular use with	Port Size - in.
247787	⅝" Modular	⅝"
247789	½" and ¾" Modular	⅜"
247791		¾"

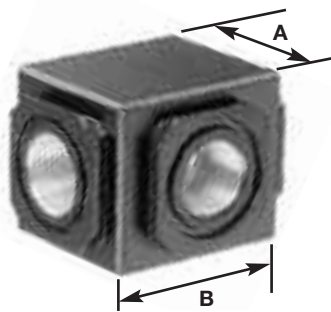

**Modular Air Line Equipment Accessories—
 Manifold Block**

Installs with quick clamps. Ports are threaded pipe to provide manifolding capability for up to three components.

Model No.	Port Size-in.	For Modular Sizes	Dimensions-in. / mm	
			A	B
247795	¾"	½" and ¾"	2.27 / 57.8	3.15 / 80



Modular Air Line Equipment Accessories— Tamper Resistant Cover & Seal Wire

Install on the adjusting knob of regulators to help prevent unauthorized adjustment of the pressure setting.

Model No.	For Modular Sizes
247777	¼" and ⅜"
247778	½" and ¾"



Modular Air Line Equipment Accessories— Wall Mount Bracket

Use to secure Modular Air Line components to a wall, machine panel or other flat surface.

Model No.	For Modular Sizes
247775	¼" and ⅜"
247776	½" and ¾"



Air Line Equipment Accessories— Mounting Bracket and Nut-Miniature

Use to secure Miniature Air Line components to a wall, machine panel or other flat surface.

Model No.	Component
247774	All Regulators and Lubricators



Air Line Equipment Accessories—Pressure Gauges

Available in ⅛" NPT and ¼" NPT back connection.

Model No.	For Regulator Sizes	Gauge Dia.	Connection	Pressure Range
247843	¼" and ⅜"	1½"	⅛" NPT	0 to 160 / 0 to 11
247844	½", ¾" and 1"	2"	¼" NPT	0 to 300 / 0 to 20
247863				

WARNING

Equipment contained in this catalog can generate very high fluid pressure. Before each use, make sure safety devices are in place and operating properly. Do not alter or modify any part of the equipment as this may cause fire, explosion, property damage, or result in serious bodily injury, including injecting fluid through the skin or splashing in the eyes. To reduce the risk of serious bodily injury or property damage, never exceed the maximum air or fluid working pressure of the **lowest rated system component**. Always read and follow the manual included with the equipment for more detailed information.

FAILURE TO HEED THESE WARNINGS MAY RESULT IN PERSONAL INJURY AND/OR PROPERTY DAMAGE.

WARNING

Pumps with ratios 1:1 to 5:1

2424, 2434, 2435, 2435LN, 2437, 485, 486, 594, 595, 596, 597, 1931, 1936, 1940, 282133, 282396, 282398, 282686, 2532, 2535, 2535LN, 2537, 282990, 284168, 284230, 284231, 284288, 284295, 284840, 284842, 282846, 284852, 284855, 284856, 284862, 284870, 285133, 285168, 285230, 285231, 285295, 285686, 285990, 84829, 84933, 84934, V305000000, V30500SSU, V305055BB, V305016DC, V305275BB, V30500SWM, V305055LT

These pumps can develop up to 1000 psi working pressure 200 psi maximum incoming air pressure. Be sure that all system equipment and accessories are rated to withstand the maximum working pressure of this pump. DO NOT exceed the maximum working pressure of the lowest rated component in the system.

WARNING

Pumps with ratios 6:1 to 49:1

930, 931, 934, 935, 936, 1901, 1902, 1903, 1905, 1906, 1909, 1914, 1932, 1933, 1934, 1937, 1938, 1939, 1951, 1952, 1955, 1996, V410000000, V406000000, V40600SSU, V40600SWM, V41000SSU, V410055DC, V410055BB, V41000SWM, V410055LB, V410055LT

These pumps can develop 7840 psi working pressure at 160 psi maximum incoming air pressure. Be sure that all system equipment and accessories are rated to withstand the maximum working pressure of this pump. DO NOT exceed the maximum working pressure of the lowest rated component in the system.

WARNING

Pumps with ratios 50:1 to 75:1

918, 923, 926, 1418, 1426, 1904, 1910, 1911, 1935, 1941, 9917, 9989, 82050, 82054, 82716, 82991, 83122, 84683, 84684, 84667, 84668, 85791, V350120000, V350400000, V350400DC, V305275BB, V350120DC, V350120HF, V350400HF, V350120LT, V350400LT, V4501200000, V4504000000, V450120DC, V450400DC, V450400HF, V450400HR, V450120LT, V450400LT

These pumps can develop 11250 psi working pressure at 150 psi maximum incoming air pressure. Be sure that all system equipment and accessories are rated to withstand the maximum working pressure of this pump. DO NOT exceed the maximum working pressure of the lowest rated component in the system.

IMPORTANT: Accessory item “whip” hoses for dispensing valve are fluid pressure rated 4500 psi. DO NOT exceed 90 psi air pressure to pump when using “whip” hoses.

DO NOT USE ANY WHIP HOSE WITH ANY PUMP RATED OVER 50:1 RATIO.

WARNING

Models 1272, 1273D, 1276, 1292, 1297

Be sure that all accessories are rated to withstand the maximum working pressure of the pump. DO NOT exceed the maximum working pressure of the lowest rated component in the system.

WARNING

Swivel Models 80353, 80924, 81386, 81387, 81388, 81606, 81703, 81723, 81728, 81729, 81974, 82071, 82072, 82073, 82080, 82087, 82249, 82251, 82252, 82399, 82677, 83594, 82822, 83938

MATERIAL USE: Lincoln swivels are to be used only to transport grease, oil and other lubricants and are designed only for these non-abrasive and non-corrosive purposes. DO NOT use with abrasive and corrosive materials such as sound-deadening materials which may contain limestone and mica particles. Transport of such materials causes rapid premature wear to critical swivel components and can cause failure of swivel. Failure could expose the user to severe bodily injury, permanent disfigurement or death.

INSTALLATION & SERVICE: Tighten all fluid connections securely before using swivel. Never exceed 5000 psi maximum operating pressure. Never alter or modify any part of the swivel. Never attempt to repair or disassemble the swivel while the system is pressurized. Never stop or deflect leaks with hand or body.

MEDICAL ATTENTION: Get medical attention immediately if exposed to high-pressure fluids. Tell the attending physician what was injected.

Lubrication Tools and Equipment

Numerical Index



Model No.	Page No.
G100	IBC
G102	IBC
G110	IBC
G112	IBC
G113	IBC
G150	IBC
G160	IBC
G212	IBC
G212S	IBC
G218	IBC
G218S	IBC
G300	IBC
G310	IBC
G321	IBC
G600	IBC
G601	IBC
G800	IBC
G901	IBC
G904	IBC
G905	IBC
G907	IBC
K00000SSU	6, 7
K000016DC	6
K000055BB	6, 7
K000055DC	7
K000055LB	7
K000055LT	6, 7
K000275BB	6
K050120DC	4, 5
K050120LT	4, 5
K050400DC	4, 5
K050400LT	4, 5
K40600SSU	7
RPM 8	35
RPM 10	35
V30500SSU	6
V30500SWM	6
V305016DC	6
V305055BB	6
V305055LT	6
V305275BB	6
V350120DC	4
V350120HF	4
V350120LT	4
V350400DC	4
V350400HF	4
V350400LT	4
V40600SSU	7
V40600SWM	7
V41000SSU	7
V41000SWM	7
V410055BB	7
V410055DC	7
V410055LB	7
V410055LT	7
V450120DC	5
V450120LT	5
V450400DC	5
V450400HF	5
V450400HR	5
V450400LT	5
V305000000	6
V350120000	4
V350400000	4

Model No.	Page No.
V406000000	7
V410000000	7
V450400000	5
V450120000	5
V4504000000	5
V4501200000	5
212	IBC
213	IBC
214	IBC
218	IBC
219	IBC
224	21, IBC
346P	22
500L	28
527	33, 34
527A	34
535	33, 34
535LN	34
535-58	34
549	34
549-58	34
613	38, 39
615	39, IBC
674	22, 25, 34
740	22, 44, 50, IBC
758	51
758F	51
769	51
774	51
775	51
776	51
779	51
780	33, 34, 51
815	22, 23, 24, 29, 30, 33, 35, 44, 54, 55, 57
816	21
840	54
844	21
845	54
846	44, 51, 54
867	52
876	52
877	52
878	52
881	52
883	52
899	52
905	52
905SF	52
917	22
917-57	22
918	24
926	24
926-1	24
939	57
940	54
950	54
952	35, 36, 52
953	52
954	35, 52
960	54
967	35, 52
987	22
989	22

Model No.	Page No.
1013	13
1035	13
1037	13
1100CLR	14
1107CLR	14
1132	12, IBC
1133	12, IBC
1134	11, 14
1134CLR	14
1142	12, IBC
1142CLR	14
1145	13
1147	12, IBC
1148	11, 12, IBC
1148CLR	14
1151	12
1162	13
1163	13, 15, IBC
1163CLR	14
1200	10
1201	10
1202	10
1203	10
1210	10
1211	10
1215	10
1215A	10
1218	10, 13, 15
1224	10, 15
1227	10
1230	10, 15
1236	10, 15
1240	10
1240CLR	14
1242	10
1244	10
1253	33, 34
1253LN	34
1254	33, 34
1272	27
1273D	27
1275	27
1292	27
1293	33, 34
1296	28
1326	37
1335	37
1400	9
1401	10
1410	10
1414	10
1415A	10
1418	24
1426	24
1426-1	24
1440CLR	14
1442	9
1444	9
1716	26
1901	32
1903	26
1904	26
1908	26
1910	26

Lubrication Tools and Equipment

Numerical Index



Model No.	Page No.	Model No.	Page No.	Model No.	Page No.
1914	32	5184	18, IBC	10199	44, 49
1952	32	5185	18, IBC	10200	49
2424	30	5186	18	10202	44, 49
2435	33, 34	5190	18, IBC	10204	49
2435LN	34	5191	18, IBC	10460	17
2437	30	5200	19	10461	20
2524	30	5200C	19	10462	23 , 44
2535	33, 34	5210	19	10462-9	44
2537	30	5210C	19	10522	49
3029	15	5290	18, IBC	10536	17
3034	15	5291	18, IBC	10540	44
3050	44, 50	5300	19	10773	44
3601	40	5300C	19	10787	20
3605	38 , 39	5318	19	11107	44
3608	39	5350	19	11197	44
3609	38, 39	5350C	19	11485	20
3610	39	5385	19	11509	20
3613	39, 40	5385C	19	11659	22, 23, 24, 29, 30, 35, 54, 55 , 57
3614	39, 40	5400	19	11660	55
3624	40	5400C	19	11661	55
3644	39	5410	19	11852	49
3866	52	5410C	19	12106	44
3867	52	5468	18, IBC	12287	49
3868	52	5469	18	12957	44, 49
3942	52	5470	18, IBC	13329	55
4100	38, 42	5490	18, IBC	13331	55
4105	42	5491	18, IBC	14727	44
4106	40	5527	19	20026	20
4110	42	5527C	19	20028	20
4262	35	5706	19	20029	20
4265	35	5803	17, IBC	31138	17
4283	35	5806	17	46007	3, 22, 24, 25 , 29
4417	23	5812	15, IBC	58000	17
4459	23	5818	15, IBC	62028	17, IBC
4489	23	5834	13, 17 , 27	62061	17
4475	36	5845	15, 16 , 17, 50, IBC	62117	17
4480	36	5848	16 , 17, IBC	66060	25
4490	36	5849	17	66100	58
4491	35, 36	5852	11, 12, 16 , 17, 27, IBC	66101	58
4492	36	5852-2	16, IBC	66111	58
4493	35	5852-5	16	66493	38 , 42
5000	19	5852-54	16	66584	51
5000C	19	5853	12, 13	66764	26 , 32
5003	19	5855	17, IBC	66951	44, 54, 57
5003C	19	5858	15	66953	20, IBC
5010	19	5859	17, IBC	67020	12
5010C	19	5861	15, 50	68410	52
5013	19	5862	55	68620	42
5013C	19	5874	3, 4, 5, 6, 7, 55	70526	38, 39
5031C	19	5875	3, 4, 5, 6, 7, 55	71512	15, IBC
5033	19	5876	55	71518	12, 15 , IBC
5033C	19	5883	16 , 17, 20	72024	29, 45, 49
5050	19	5884	17	72024A	6, 7, 45, 49
5050C	19	5980	54	72036	24, 31, 42, 49
5175C	19	5983	57	72060	30, 31, 49
5176C	19	5990	54	72120	49
5177C	19	9917	3 , 4	72240	49
5178C	19	9989	3 , 4	72360	44, 45, 49
5179C	19	07201	41	72360A	44, 49
5180	19	07205	41	72480	45
5180C	19	07300	41	72480A	45, 49
5181C	19	07400	41	72600	44, 45, 49
5182C	19	10198	4, 5, 44, 49	72600A	44, 45, 49
5183C	19				

Lubrication Tools and Equipment

Numerical Index



Model No.	Page No.
73024	.6, 7, 29, 44, 45, 49
73036	.31, 49
73060	.6, 7, 30, 31, 34, 49
73120	.49
73240	.45, 49
73360	.44, 45, 49
73480	.45, 49
73600	.44, 45, 49
73720	.44
73900	.49
74024	.44, 45, 49
74060	.49
74480	.45, 49
74560	.34
74600	.44, 45, 49
74720	.44
75024	.44, 45, 49
75060	.4, 5, 24, 49
75084	.3, 22, 49
75120	.49
75168	.49
75240	.45, 49
75360	.44, 45, 49
75480	.45, 49
75600	.44, 45, 49
75912CL	.15
75918CL	.15
75924CL	.15
75936CL	.15
76024A	.45, 49
76024B	.45, 49
76120B	.49
76360B	.45, 49
76600A	.45, 49
76600B	.44, 45, 49
76900B	.49
78024	.45
78600	.45
79060	.27
80133	.28
80202	.4, 5, 24, 25
80423	.57
80599	.34
80895	.3, 22, 25, 34 , 38
80924	.27
80933	.15, 17 , 27
80999	.34
81168	.27
81386	.50
81387	.3, 22, 44, 50 , IBC
81412	.26
81458	.15, 17 , 27
81523	.24, 25
81538	.26
81606	.15, 50
81673	.27
81703	.50
81723	.50
81725	.15, 50
81726	.15, 50
81728	.50
81729	.44, 50
81768	.27
81795	.15, 50

Model No.	Page No.
81974	.50
81980	.15, 17
82050	.22, 24
82054	.24
82070	.51
82072	.50
82073	.50
82080	.50
82087	.50
82157	.50
82158	.50
82206	.45
82230	.37
82251	.50
82252	.50
82258	.53
82399	.3, 22, 50
82413	.59
82439	.31, 32
82460	.38, IBC
82716	.22
82730	.26, 32
82757	.33, 34
82760	.12
82784	.17, IBC
82786	.39
82790	.32
82792	.26
82895	.32
82906	.51
82932	.51
83115	.5, 6, 7
83131	.7
83132	.32
83201	.47
83202	.47
83203	.47
83206	.47
83271	.26
83278	.17
83366	.24, 25
83369	.26
83386	.38, 39
83447	.24, 30
83463	.45
83463-30	.45
83464	.45
83464-50	.45
83513	.22
83594	.50, IBC
83753	.48
83754	.48
83938	.50
84122	.48
84191	.25, 34
84192	.25, 34
84257	.48
84275	.46
84335	.32
84347	.45, 48
84377	.25, 34
84432	.46
84538	.29, 30, 31
84606	.57

Model No.	Page No.
84667	.24
84668	.24
84672	.46
84673	.46
84700	.42
84714	.38, 42
84775	.3, 22, 25
84780	.3, 4, 5, 21, 22, .24, 25 , 26, 28
84799	.52
84815	.42
84816	.42
84817	.42
84824	.42
84826	.32
84829	.4, 5, 37
84933	.29, 30
84934	.29, 35
84935	.29, 31
84940	.29, 31
84941	.25, 29, 31
84945	.6, 7, 29, 31, 32
84946	.29, 31, 32
85001	.45
85002	.45
85002A	.45
85003-30	.45
85004	.45
85004-50	.45
85004-50B	.45
85005	.45
85006-30B	.45
85008-50A	.45
85009-50	.45
85010-50	.45
85011	.45
85021	.50
85232	.45
85255	.42
85387-4	.61
85387-6	.61
85387-8	.61
85387-12	.63
85387-16	.63
85388-4	.61
85388-8	.61
85388-12	.63
85389-8	.62
85389-12	.63
85389-16	.63
85515	.44, 45, 48
85516	.44, 45, 48
85517	.44, 45, 48
85627	.37
85632	.37
85672	.64
85674	.65
85716	.29, 30, 31
85755	.29, 31
85765	.29, 31
85791	.3, 4
85792	.3, 4
85799	.53
85806	.6

Lubrication Tools and Equipment

Numerical Index



Model No.	Page No.	Model No.	Page No.	Model No.	Page No.
85807	6, 7	247748	38	600212	59
85824	6, 7	247770	65	600216	59
85826	4, 5, 6	247771	65	600301	59
85827	4, 5, 7	247772	65	600401	35, 58
85840	5	247774	67	602003	23, 36, 64
85935	29, 31	247775	67	602004	60
85949	6, 29, 30, 31, 35	247776	67	602005	60
87334	35	247777	67	602006	60
87354	35	247778	67	602007	60
89010	46	247782	65	602008	60
90464	52, 53	247783	65	602009	60
90656	22	247787	66	602012	62
90776	20, IBC	247789	66	602013	62
91108	12, 28, IBC	247791	66	602016	62
91197	39	247792	66	602103	64
91241	53	247793	66	602104	60
91392	51, 53	247795	66	602106	60
91499	22	247843	23, 58, 67	602108	60
92572	42	247844	58, 67	602109	60
93547	34, 53	247863	58, 67	602112	62
93548	52, 53	260379	53	602113	62
94000	35	260380	51, 53	602116	62
94100	44	260381	51, 53	602117	62
94132	44	273036	36	602134	61
94132A	44	273037	36	602136	61
94132W	44	273299	4, 5, 6, 7	602138	61
94133	44	274790	28	602203	64
94133A	44	274932	4	602204	60
94133W	44	275172	48	602206	60
94152	44	275173	48	602208	60
94152A	44	275184	27	602212	63
94152W	44	275260	4, 5	602216	63
94153	44	275370	3	630104	56
94153A	44	275398	6, 7	630204	56
94153W	44	275413	6, 7	632004	56
94154	44	275415	4, 6, 7	640104	56
94154A	44	275416	5	640106	56
94154W	44	282133	30	640204	56
94163	44	282396	29, 30	640206	56
94300	44	282398	29, 30, 35	642006	56
94334	35, 44	282876	31, 32	650108	56
94354	35, 44	282902	31	650208	56
94364	44	282930	51	652008	56
94500	44	282941	51	1230120	49
94532	44	284168	30		
94532G	44	285133	30		
94552	44	285168	30		
94552G	44	285231	30		
94553	44	600003	35, 58		
94553H	44	600004	42, 59		
102697	21	600006	59		
102891	21	600008	59		
102929	21	600012	59		
103307E	20	600016	59		
103308E	20	600103	58		
103309E	20	600104	42, 59		
237105	40, 42	600106	59		
241408	40	600108	59		
241409	40, 42	600112	59		
241584	6, 7, 29, 30	600116	59		
241937	37	600203	58		
242503	51	600204	42		
242911	53	600206	59		
244390	38	600208	59		

Lubricating Tools & Accessories Display Centers



Model 218
Lincoln 2-Sided
Merchandiser
Display
24" x 72"



Model 219
Lincoln/Guardian
2-Sided Combo
Merchandiser
Display, 24" x 72"



Model 212
Lincoln Mini
Merchandiser
24" x 32"



Model 214
Guardian Mini
Merchandiser
24" x 32"

**Purchase Lincoln's best selling lubrication products. . .
and we give you the merchandiser!**

MODEL	Description	212 Lincoln Mini	213 Combo Mini	214 Guardian Mini	218 2-sided Lincoln	219 2-sided Combo
1133	GUN, GREASE PISTOL	1	1		2	1
1142	GUN, LEVER	1	1		2	2
1132	GUN, GREASE PISTOL				1	
1147	GUN, LEVER				1	
1148	GUN, LEVER DELUXE	1			1	1
1162	GUN, AUTOMATIC AIR OPERATED				1	1
224	BEARING PACKER				1	
5184	FTG, MINI METRIC ASST				1	
5185	FTG, METRIC ASST				1	
5190	FTG, LUBE STR 1/8MPT QTY-10	1			1	1
5191	FTG, LUBE STR 1/4-28 QTY-10				1	
5290	FTG, LUBE 45° 1/8MPT QTY-10				1	1
5291	FTG, LUBE 45° 1/4-28 QTY-10				1	
5468	FTG, LUBE ASSORTMENT	1			1	
5470	FTG, LUBE ASSORTMENT				1	1
5490	FTG, LUBE 90° 1/8MPT QTY-10				1	1
5491	FTG, LUBE 90° 1/4-28 QTY-10				1	
5803	NEEDLE ASSY	1	1		1	1
5812	HOSE, WHIP W/SPR				2	1
5818	HOSE, WHIP W/SPR	1	2		2	1
5845	COUPLER, HYD ASSY	1	1		1	1
5848	COUPLER, HYD SWIVEL ASSY	1			1	1
5852	COUPLER, MIDGET HYD	1	1		1	1
5852-2	COUPLER, MIDGET HYD, 2 PKG				1	
5855	ADPTR, HYD ASSY				1	1
5859	ADPTR, HYD ASSY				1	1
615	GUN, SUCTION	1			1	1
62028	NOZZLE, EXTENSION				1	
66953	TOOL, EASY OUT				1	
71512	HOSE, WHIP 12"				1	
71518	HOSE, WHIP 18"				1	
740	VALVE, CONTROL ASSY				1	1
81387	SWIVEL, UNIVERS				1	1
82760	GREASE GUN HOLDER CLAMP				1	
82784	NEEDLE NOZZLE ASSY	1			1	1
83594	SWIVEL, UNIVERS				1	1
90776	TOOL, EASY OUT				1	
91108	FILLER NIPPLE	1	1		1	1
G100	GUN, GREASE STD LVR ACTI		1	1		1
G102	GREASE GUN					2
G110	GUN, GREASE, MINI PISTOL			1		2
G112	GUN, GREASE, HD PISTOL		1	1		1
G113	GUN, PISTOL GREASE					1
G150	GUN, SUCTION					1
G160	HOLDER, GREASE GUN			1		1
G212	HOSE, 12"-1/8" NPT			2		1
G212S	HOSE, 12"-1/8" NPT, W/SPRING					1
G218	HOSE, 18"-1/8" NPT			2		1
G218S	GREASE HOSE W/SPRING 18"					1
G300	COUPLER, STD		1	1		1
G310	COUPLER, HD			1		1
G321	COUPLER, SWIVEL, 360 DEG			1		1
G600	FITTINGS, DOMESTIC MINI		1	1		1
G601	FITTINGS, METRIC MINI		1	1		1
G800	GREASE, TUBE LITHIUM 2 PK			1		
G901	ADAPTER, 4" NEEDLE NOZZL		1	1		1
G904	TOOL, GREASE 4-WAY SM			1		1
G905	TOOL, GREASE 4-WAY LG			1		1
G907	FITTING, GREASE GUN LOADER					1

A complete line of lubrication solutions and industrial pumping products

At every construction site, automotive repair shop and industrial plant, maintenance and automotive service professionals need high-quality lubrication equipment and pumping products.

Lincoln offers everything you need for lubrication. Our general-purpose and heavy-duty pumps, hose reels, meters and controls, used fluid systems and hand-held lubrication products are the best in the industry.



For the nearest
authorized Lincoln
sales and service
representative, call:

Americas:

Lincoln Industrial Corp.
One Lincoln Way
St. Louis, MO 63120
1.314.679.4200
Fax: 1.314.679.4359
Fax: 1.800.424.5359

Europe/Africa:

Lincoln GmbH
Heinrich-Hertz Strasse 2-8
D-69190 Walldorf
Germany
49.6227.33.0
Fax: 49.6227.33.259

Asia/Pacific:

Lincoln Industrial Corporation
51 Changi Business Park
Central 2
#09-06 The Signature
Singapore 486066
65.6588.0188
Fax: 65.6588.3438



Lincoln Industrial Corp.
One Lincoln Way
St. Louis, MO 63120-1578

Phone 314.679.4200
Fax 314.679.4359
www.lincolnindustrial.com

Form 442940 (10/07)
© Copyright 2007
Printed in U.S.A.